

EE Times

For the creators of technology

europa

NFC extends smart cards' versatility 17



SPS Drives: the
embedded story 12

OLEDs'
industrial future 30



RATED #1
Breadth of
Product

GO DIGIKEY.COM/EUROPE

RATED #1

Availability of Product



GO



DIGIKEY.COM/EUROPE

Rated number one, Distributor Reputation - "Always has available product" by North American electronic engineers in the UBM/EE Times 2011 Distributor Customer Preference Study (June 2011). Digi-Key is an authorized distributor for all supplier partners. New products added daily. © 2011 Digi-Key Corporation, 701 Brooks Ave. South, Thief River Falls, MN 56701, USA

PUBLISHER

André Rousselot
+32 27400053
andre.rousselot@eetimes.be

EDITOR-IN-CHIEF

Julien Happich
+33 153907865
julien.happich@eetimes.be

EDITORS

Nick Flaherty
+44 7710236368
nick.flaherty@eetimes.be

Christoph Hammerschmidt

+49 8944450209
chammerschmidt@gmx.net

CONTRIBUTING EDITORS

Paul Buckley
+44 1962866460
paul@activewords.co.uk

Jean-Pierre Joosting

+44 7800548133
jean-pierre.joosting@eetimes.be

CIRCULATION & FINANCE

Luc Desimpel
luc.desimpel@eetimes.be

ADVERTISING PRODUCTION & REPRINTS

Lydia Gijsegom
lydia.gijsegom@eetimes.be

ART MANAGER

Jean-Paul Speliers

ACCOUNTING

Ricardo Pinto Ferreira

REGIONAL ADVERTISING REPRESENTATIVES

Contact information at:
<http://www.electronics-eetimes.com/en/about/sales-contacts.html>



EUROPEAN BUSINESS PRESS SA

144 Avenue Eugène Plasky
1030 Brussels - Belgium
Tel: +32 (0)2 740 00 50
Fax: +32 (0)2 740 00 59
www.electronics-eetimes.com
VAT Registration: BE 461.357.437
RPM: Brussels
Company Number: 0461357437

© 2011 E.B.P. SA

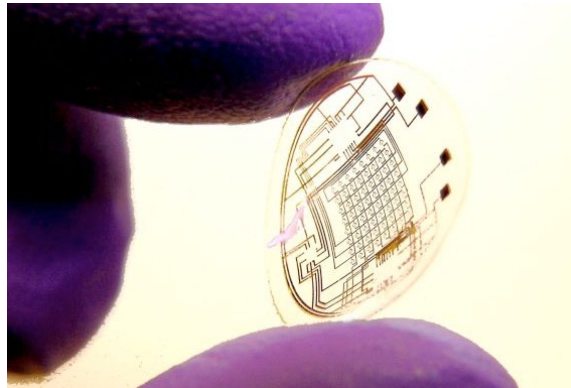

Researchers in Finland and the US have developed and tested a prototype contact lens that could provide the wearer with a real time hands-free display. The lens features an antenna, control circuitry and the interconnects for a LED microarray. **14**

OPINION

- 4 Uncommon Market:**
Taking control over your digital trail
- 50 Last Word:** Amplifiers are the hidden heroes of any system

NEWS & TECHNOLOGY

- 5** Samsung to present 8-Gbit phase-change memory
- Nokia tweaks Bluetooth for indoor navigation
- 6** Driver assistant system identifies and marks obstacles
- TeraTOP on track to develop THz passive imaging sensor
- 8** Productronica: industry forges ahead with battery technology
- 10** Intel, Google don't support Android to PC port
- 12** ARM drives into embedded applications with new module format
- 14** Wireless display in a contact lens
- Interdigitated back-contact Si solar cells with 23% efficiency
- 15** TI calls baseband a distraction, but is it?
- 16** Plastic memory firm partners with organic ink startup
- Graphene printed via ink-jet, ups mobility

DESIGN + PRODUCTS

SPECIAL FOCUS: IDENTIFICATION

- 17** NFC solutions are ramping up: not just for mobile payment
- 21** NFC-enabled phones as a tool for brand protection
- 23** Designing a compact vehicle tracking platform
- 24** Multimodal and simultaneous biometric authentication goes mobile

SPECIAL FOCUS: DISPLAY TECHNOLOGIES

- 28** Bringing P-Cap touch sensing into the handheld industrial equipment sector
- 30** Research project illuminates OLEDs' industrial future

SPECIAL FOCUS: SENSORS & DATA CONVERSION

- 34** Increasing system performance through optical encoders
- 36** Hyperspectral imaging: seeing the invisible
- 38** Integrated sensor nodes with GSM modems
- 40** Sensing electrical potentials for touchless control

READER OFFER

- 46** Marvell gives away 4 plug computer kits

Taking control over your digital trail

By Julien Happich

EVERY DAY, THE ONLINE MARKETING industry, intertwined with search engines, social networks and mass self-communication platforms (such as blogs, social tagging, twitter), exchanges vast amounts of raw personal data across the globe.

New internet concepts such as immaterial labour 2.0, at the core of automated profiling and targeted advertising, rely on user-selected/recommended or user-created page builds to foster more website interactions and more page views (read advertising opportunities). Europe makes a tantalizing market place of 500 million people and in 2009 the web advertising expenditure focusing on this market was estimated to reach €14.7 billion, according to the Internet Advertising Bureau.

Behind these figures, the harvesting of Personal Identifiable Information (PII) and data-sharing are the key drivers of most social-media and search engine applications, enabling the monetization of user-generated content and its segmentation into marketing niches. To what extent is this affecting our fundamental rights, in terms of privacy, in terms of choices and freedom? Does the loss of privacy for the access to free services empower us more than it disempowers us?

These were some of the questions raised last week by Rob Heyman, PhD student of IBBT-SMIT (Interdisciplinary institute for BroadBand Technology - Studies on Media, Information and Telecommunication) at a lecture held at the Université Libre de Bruxelles (ULB). Heyman is involved in the EMSOC project (user EMpowerment in a SOcial media Culture - www.emsoc.be), whose goal is to critically assess the belief of the user being empowered in a social media culture. Running from 2010 until 2014, the research is structured according to three main areas of interest in society where user (dis)empowerment is taking place related to social computing: inclusion, literacy and privacy.

As Heyman explains, although privacy concerns seem to be ignored if anonymous information is shared with third parties, finely-tuned data mining makes it possible to re-identify users through the linkage of separate pieces of anonymous information, leading to “dataveillance” or surveillance through data harvesting. The loss of control over

personal information comes from the fact that most consumers do not know what information has consequences because they do not know who is gathering it and how exactly it will be used. What’s more, all the data harvesting processes are mostly driven automatically, often without the user’s explicit consent. Taking StumbleUpon and Google as examples, Heyman highlighted the fact that some websites use algorithms to selectively guess what information a user would like to see based on information about the user’s likes, past click behaviour and search history.

This automated content filtering somehow alters the users’ view of reality, as it is reconstructed for each individual person, steering web users through invisible calculations (optimised for advertising delivery and click-through rather than to follow a genuine quest for information). Users become part of the delivery mechanism, without necessarily knowing how their actions affect the content they access.

On one hand they are empowered and able to do much more than before, but on the other hand through this immaterial labour 2.0, the personal data they generate also empowers social media platforms to produce revenue, via user-generated ‘sponsored’ web-pages that will also be liked or disliked and shared within the user’s community.

Of course, you would rather see advertising that is relevant to your favourite topics, but since the boundary of advertising is lost, users are no longer able to understand that what they are viewing is not part of the user-generated content but part of a marketing campaign. Heyman also raised the question about the personalisation of Google search results: if in an algorithm is used to personalize search results based on the personal data collected (without making clear what data and what logic it follows), the information bias could amount to a form of personalized censorship. There is often a denial of this downside and in a previous paper “Social



media and cookies: challenges for online privacy”, Heynman’s research shows how user disempowerment in social media is often overlooked by overstressing their beneficial potential. Hence, is immaterial labour 2.0 a fair deal? Only if the users clearly understand what kind of deal they have entered and how they can control the way their personal data is used.

This could fall within the scope of a new European law on data protection, to be proposed in January by Viviane Reding, European Commissioner for Justice and Fundamental Rights. In a speech she gave at the 2nd Annual European Data Protection and Privacy Conference in Brussels last week, Reding emphasized the need to enhance users’ trust, by giving them an easier access and control over their own data, ensuring that individuals are always in a position to take informed decisions about how their personal data is used.

Users should also be provided with better data portability so they could port or transfer their data from one provider to another and Reding re-introduced the notion of right-to-be-forgotten as a key element of this new law, for if users no longer want their data to be stored. “People shall have the right, and not only the “possibility”, to withdraw their consent to the processing of their personal data”, she added.

Facebook’s recent launch of a photo tagging suggestion feature through the use of automated facial recognition software only stirred further debate over privacy issues. The company is threatened with legal action in Germany and the EPIC (Electronic privacy information center - www.epic.org) has a complaint pending before the US Federal Trade Commission over Facebook’s use of such technology to build what could be a secret database of users’ biometric data.

With more than 100 million photos tagged on Facebook every day, this sort of technology only adds to the depth of the data being collected and could extend into the field of augmented reality as seen through camera-enabled mobiles, from objects and places to people. ■

Samsung to present 8-Gbit phase-change memory

MEMORY TECHNOLOGY

By Peter Clarke

SAMSUNG ELECTRONICS IS SET to re-ignite debate about whether phase-change memory is commercially viable with the presentation of an 8-Gbit, 20-nm device at the 2012 International Solid-State Circuits Conference. The development was not unexpected as Samsung engineers were due to present a 20nm phase-change random access memory cell at the International Electron Devices Meeting which took place in Washington DC in December.

Nonetheless a 20-nm, 8-Gbit phase-change random access memory is a large jump forward from the previous state of the art. In February at ISSCC 2011 Samsung engineers presented a 1-Gbit phase-change memory implemented in a 58-nm manufacturing process technology equipped with a low-power double-data-rate non-volatile memory (LPDDR2-N) interface.

Samsung – and Micron Technologies, through its acquisition of Numonyx NV – are the only two companies that have got close to offering non-volatile phase change

memory for commercial use, despite years of research and development. And even so there are almost no reports of phase-change memories in the field. Samsung is now set to present a large device in a 20-nm process technology operating at 1.8-V and with a 40-Mbyte/s programming bandwidth. This puts phase-change memory at close to the same geometry and memory cell density as NAND flash.

The ability within NAND flash to store and detect multiple bits per cell still gives flash a memory capacity advantage over PCM. Flash memory is also expected to go to a form that could stack multiple memory cells vertically, providing further memory capacity scaling. Phase-change memory works by detecting the change in resistance of a chalcogenide alloy as it moves between amorphous and crystalline states under the action of resistive heating. It has long been hoped that the technology could combine the scaling advantages of a cross-point

memory with the non-volatility of flash memory while offering superior endurance and bit addressability.

However, PCM has hit a number of barriers to deployment, not least the ability to get ahead of the fast scaling of NAND flash memory. Technical challenges to PCM continue to exist over the ability of the heating effect to scale both within the memory cell and due to thermal cross-talk effects on neighbouring cells. There are also concerns on whether this sensitivity to temperature could prevent pre-programmed phase-change memories being taken through printed circuit board production processes such as solder baths.

The rules of ISSCC always were that papers could only be accepted if researchers had made real devices and taken physical measurements – in other words no simulation papers or ones based on design data. However, it was not necessary that devices worked fully or as intended. ■

Nokia tweaks Bluetooth for indoor navigation

By Rick Merritt

NOKIA RESEARCH IS COURTING partners and expanding Bluetooth as part of an initiative on indoor location-based services. The company aims to leverage its handset and mapping products to enable a wide range of services including indoor navigation and retail analytics.

“We want to take what’s been done in navigation outdoors and bring it inside,” said Fabio Belloni, a principal researcher in Nokia’s radio systems lab that looks for new ways to use networks.

Nokia has two pilots using a new Bluetooth protocol in the works and has reached out to as many as 30 companies in an effort to set broader standards that ultimately

may include Wi-Fi and other networks. The company is leading work on a new Location Extension protocol to ride on top of Bluetooth 4.0. It could be issued as a standard by the Bluetooth Special Interest Group in about 18 months.

The company designed a prototype based on a room outfitted with Bluetooth Low Energy antenna arrays that track devices with Bluetooth tags.

The prototype uses triangulation to create 3-D maps of a room. Researchers envision equipping malls, exhibit halls and other large buildings with the antenna arrays to help people navigate through them. They also foresee large stores using tagged

carts to track and study shopper behaviour.

The Bluetooth arrays could be inexpensive, and ultimately they could be integrated as a feature into Wi-Fi access points the buildings already use, said Belloni.

Nokia gathered about 30 companies including chip and system makers and service providers to an event to roll out its concepts. It hopes to create a formal group that could help set global standards for such indoor navigation services.

The demo was one of several marking the 25th anniversary of the Nokia Research which is now setting up a new satellite office here. ■

Driver assistant system identifies and marks obstacles

By Christoph Hammerschmidt

RESEARCHERS OF THE KARLSRUHE

Institute of Technology (KIT) have developed a night vision system that goes one step further than existing infrared-based vision systems: It does not display potential obstacles. Instead, it illuminates the object directly by means of a bright spotlight. To see and to be seen is an important rule for safety in particular during twilight or night time on remote country roads. "During dusk and dawn, the likelihood of getting involved into an accident with pedestrians, cyclists or game animals rises exponentially," explained KIT researcher Marko Hoerter who works at the KIT institute for measuring and control technology. While systems are available that make such objects visible on a screen, they are not very practical, finds Hoerter, since they require that the driver actively watches out for them during the ride which is less than optimal

from the perspective of safety. Hoerter has developed an infrared camera-based system which analyzes the image content, identifies any objects in the course of the car and illuminates them shortly with a highly focused LED-based spotlight. This directs the driver's attention to the respective object without requiring that drivers deviate their eyes from the road. The centerpiece of the system is a camera and a powerful computer that processes the video data stream. The challenge was the huge amount of data to be processed in real-time, Hoerter explains. The image processing computer used in the system can tell animals and humans from other objects within 40 milliseconds. In addition, it can transform and determine the real 3D position, direction and speed of these objects from the data contained in the 2D infrared images and the speed at which they change. Based on the results of these calcula-



tions, the system also computes the probability of an accident. If there is a significant probability of an impact, a motor-driven apparatus directs the spotlight to the object in question. The system does not generate a continuous light but instead illuminates the object only for a short period in time to avoid bedazzling the person in question.

The approach has been tested during a field trial in a rural environment with 33 participants. The results were encouraging: The light marker enables one to recognize obstacles earlier and faster. On average, the drivers saw the obstacle 35 to 40 meters earlier. Consequently, they had two to three seconds more time to react. ■

European project TeraTOP on track to develop THz passive imaging sensor

By Julien Happich

THE TERATOP PROJECT's main objective is to develop a device that has the potential to reduce the cost and improve the capability of terahertz (THz) imaging in a wide range of applications including public security. A consortium of eight European industrial research groups and companies, TeraTOP focuses on potential security applications and will demonstrate a camera for detecting hidden objects. Complimentary Metal-Oxide Semiconductor (CMOS) technology has recently seen a vast development effort in the higher frequency regimes of the near-infrared and the visible parts of the spectrum. The resulting technology has generated substantial business volumes – in excess of €4bn in 2009 at the component level alone. The development of an analogous capability for the THz range currently relies on exotic materials and technologies and has been impeded by the lack of devices and circuits

suitable for mass production. The consortium plans to implement a completely new type of THz sensor based on thermally isolated nanotransistors directly integrated with CMOS-SOI (Silicon On Insulator) read-out circuitry. The THz region of the electromagnetic spectrum is attracting increasing attention from scientists around the world. Extending from the microwave- to the infrared region, this non-ionizing (and therefore safe) radiation can be used to see beneath outer layers of packaging and clothing.

The key target of the project is to make breakthrough advances in the functionality, performance, cost, and size of a passive THz camera. The target technology is a room temperature real-time imaging system based on CMOS batch manufacturing processes which are suitable for mass production. The key enabling building blocks include: THz photonic components, THz antennas,

CMOS-SOI, NEMS, and frequency-selection technologies from the astronomy community. Underlying the project are several important THz related patents and patent applications submitted by two of the project partners: Technion – Israel Institute of Technology – and IBM Haifa Labs.

The project is funded by the European Commission's 7th framework and has a total budget of €3.15M. It is led by Dr. Nicolas Blanc of CSEM (Switzerland). The consortium consists of: CSEM (Switzerland), Technion Israel Institute of Technology (Israel), IBM Haifa Research Lab (Israel), IBM Research GmbH (Switzerland), CEALLETI (France), the University of Wuppertal (Germany), EADS Deutschland GmbH (Germany), and QMC Instruments Ltd. (UK). Additional leading experts in the field of THz technology will form an external advisory board to assist the consortium. ■



mouser.com
Distributing semiconductors and electronic components for design engineers.

Authorised Distributor



It's **hip**
to be
square.

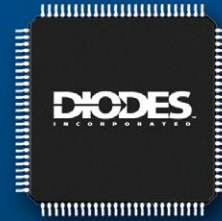
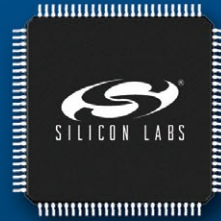
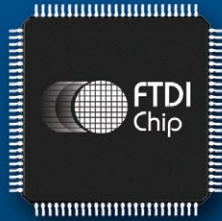
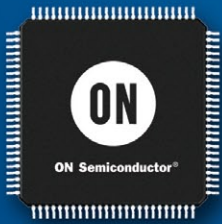
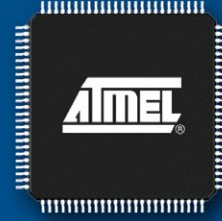

Advanced **semiconductor** solutions to fuel your creativity.

Come to Mouser first for what's next from these industry leaders.



Germany (European Headquarters)

Elsenheimerstr. 11, 80687 Munich
+49 (0) 89 520 462 110
munich@mouser.com

The Newest Products for Your Newest Designs®



a tti company

Productronica: industry forges ahead with battery technology

By Christoph Hammerschmidt

THE MARKET FOR electric vehicles will be one of the hottest and most competitive ones for the high-tech industry around the globe. More and more, the insight prevails that the batteries for electric cars will be the key to market leadership. Their quality will determine the most critical parameters of future e-car generations: driving range, weight, price, and reliability - all together, these parameters define the suitability for everyday use and thus for the market success of battery powered vehicles including hybrid electric concepts.

For the German industry it is not sufficient to develop the best battery technology, it will also be necessary to mass-produce these batteries at an industrial level, given the fast growth expectations in this market. At the recent Productronica electronics production trade fair, a special show displayed the state of development in battery production technology. At a huge booth organized by the machinery industry association VDMA, companies and research institutes exhibited how the large-volume powertrain battery production of the future will look like and what has been achieved so far.

When it comes to electric driving, the German automotive industry currently lags behind their Japanese and North American competitors. The management of vendors such as Volkswagen, Daimler, or BMW has recognized that they will have to catch up or perish. Experts such as Roland Berger Strategy Consultants believe that there is a good chance the European industry can pass their Far Eastern competition in the mean term. The Roland Berger study predicts that in 2025, the market acceptance for electric cars will be higher in Europe than in any other geography: 12 percent of all cars will run on batteries in Europe. Japan and Korea will follow with a share of 10 percent while Northern America will lag behind with 7 percent. On the way towards this goal, competitive batteries will be a key factor. From today's perspective, Roland Berger's forecast might look a little bit a risky, but given Germany's traditional strength in precision manufacturing, it might not be impossible.

"Fifty percent of the battery cost will be associated to manufacturing," explained Eric Maiser who heads the VDMA forum on battery production. "We can reach this goal if we develop intelligent production technologies which help reduce costs."

In order to reach this goal, the industry has launched a coordinated effort to bring lithium ion batteries to volume production maturity. The Productronica special show "Battery manufacturing and power electronics" brought together manufacturing companies such as Digatron Industrie-Elektronik, ERSA, IBG Automation, OMT, Kuka Roboter, Reis Robotics, Siemens and Viscom. Researchers from the RWTH Aachen technical university contributed a "virtual factory",



Batteries are the critical success factor for electromobility - not only for this eWolf Alpha SR1 electric racing car.

functional simulation of the processes. This made not only the processes and sequences visible but also enabled factory designers to plan the layout and interactively build a virtual factory. The software is realistic enough to take into account the costs of each production process step and thus develop cost scenarios.

The battery value chain is rather complex, with a dozen process steps between the lithium powder at the start and the battery pack at the end. Today, there is no alternative to lithium for high power density batteries, said Christoph Deutschens, researcher from the RWTH technical university. At the other

end of the value chain however, the product might be very different, depending on the target vehicle. For a hybrid electric vehicle, a cell optimized for fast charging might be appropriate, while for a battery electric vehicle, constant power output will be a more relevant parameter. These different requirements result in different chemistry and different manufacturing processes. One of the most critical process steps is coating. In a roll-to-roll process, the lithium slurry is spread to the carrier material - the layer is just 100 micron thick. The evenness of the active layer is a critical factor for the longevity of the battery. At Productronica, this process step was demonstrated by surface technology expert company OMT GmbH. The coated foils are then cut into electrode sheets. Again, the challenge in this process is to create even surfaces without any burrs: uneven surfaces or, even worse, burrs can cause damage in the battery - even a tiny short circuit can quickly set a lithium ion battery on fire, an engineer from equipment machinery vendor Manz explained at the booth.

The next step is stacking the electrodes along with extremely thin separator foils into battery packs. In this step, demonstrated by Manz and Duerr AG, manufacturing precision still is a challenge. The cell packages are then filled with electrolyte. In order to turn a battery pack into a 'live' battery, the device needs to be charged and discharged several times. This process takes several weeks; the formation racks in industrial-grade production lines always contain many daily productions - a huge value. All these process steps are not perfect yet; there is some potential for throughput and speed improvements, says Maiser. But he sees a good chance that the European equipment providers could pass their competitors in Japan and Korea: many machinery manufacturers have gathered their experience in a similar industry: in the photovoltaics business. And although the German PV industry currently has a hard time to compete with Asian manufacturers, the equipment providers still benefit from this market. ■

A real broadside!

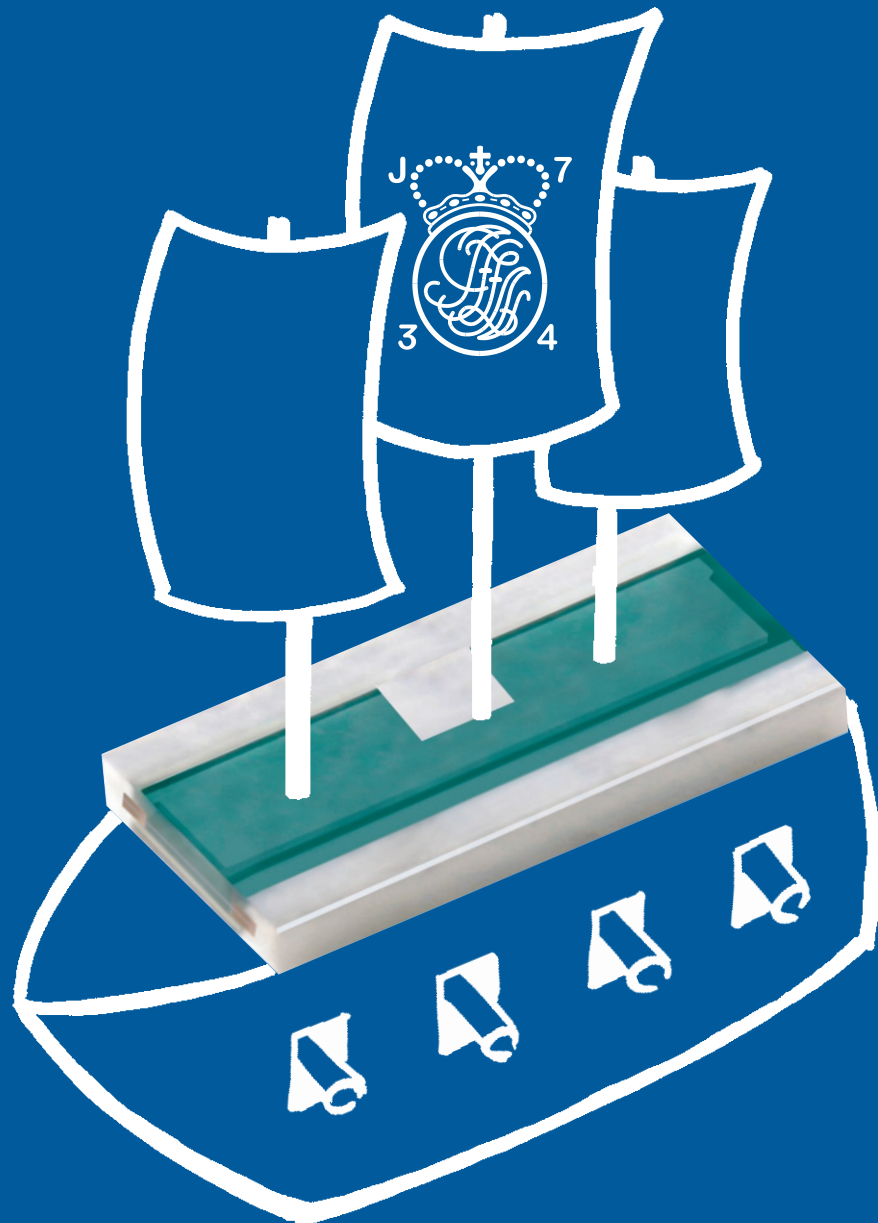

Top performance on small surface areas with low-ohmic precision resistors

By reversal of the length to width ratio, our VLx series resistors have larger soldering and contact pads, giving them:

- better heat dissipation, $R_{thi} < 20K/W$
- higher power rating: 2 W for size 1020, 1 W for size 0612
- significant increase in mechanical stability



ISABELLENHÜTTE

Telephone: +49 (27 71) 9 34-0
sales.components@isabellenhuetten.de
www.isabellenhuetten.de

Innovation from tradition

Intel, Google don't support Android to PC port

By Sylvie Barak

A DEVELOPER IN TAIWAN has been making internet waves with his new but unauthorized release of a Google Android Ice Cream source code for x86 devices, aimed specifically at PCs.

Chih-Wei Huang runs the Android-x86 group, which is not part of Google's official Android Open Source Project (AOSP). Instead, Huang's initiative is being funded and supported by Intel Corp's chip rival Advanced Micro Devices Inc. (AMD).

Neither company has made any significant inroads into the smartphone or tablet market, but Intel has been making significant efforts on the mobile front, with plans to release Atom based smartphones and more commercially appealing tablets within the first half of 2012.

Intel has also spent a year and a half working directly with Google Inc. to port the Android OS to x86. The port was first achieved on Android version 2.3.7 (Gingerbread) with Intel's manager of the Google Program Office, Alec Gefrides, saying the firm had submitted some 120 patches to Google, which had all since been integrated into the source code, freely available on AOSP.

Intel's code contributions have also been carried forward into the Ice Cream Sandwich build. "We've been working with Google for a long time," said Gefrides, explaining, however, that Intel's efforts were squarely aimed at smartphones and tablets, not PCs, for which different drivers would be needed to make all the components work.

"If you pull the x86 version of Android down from the AOSP and compile it, it will run on any x86 device, but that's not the intent, neither ours nor Google's," said Gefrides. "Our focus is to get phones and tablets on our Atom product line up and running on Android. That's what we've been focused on, that's what we've been working with Google on."

Intel typically sends out board support packages to OEMs building products on its reference design which would have all the necessary drivers included. Without these drivers, certain parts would simply not work. "We could definitely get our drivers to go and do that, but it's not our focus," he said.

All parties officially using and experimenting with a variant of Android sign an agree-

ment with Google to say they will contribute everything back to the firm's open source project, to avoid such fragmentation. Intel is signatory, AMD on the other hand is not.

Huang's non-authorized version has not been submitted to Google for integration into the wider Android open source effort, which has raised concern that it could cause fragmentation.

AMD has also seemingly gone out of its way to provide resources for Huang, who notes in a forum thread, "AMD provides great support to us, including device donation and engineer's support." Huang complains that Intel, on the other hand, does not support his efforts to port Android to PCs.

"Intel still refuses to provide any help to this project. They closed all contact windows I've ever tried," said Huang, going on to recommend to his followers that should they want his code to work, he recommends using it on an AMD platform.

An Intel spokeswoman told EE Times there was no way the company could support the fragmentation of the Android platform, nor would Intel want to go against Google's intent for how its Android platform best be used. Intel has also been very clear that its focus for Android is on Atom, as opposed to its Core products.

Intel's investment in open source

"We're happy, this is an open source community, we're excited for people to go off and start their own projects," said Gefrides, but noted that while the project remained outside of the AOSP, it was nothing but an unofficial experiment.

Asked if Intel would reconsider its position should Huang's port prove popular on a PC, Gefrides said it was impossible to predict. "At this point, who knows whether Android will ever end up on a PC or not," he said, noting that Google already had its own Chrome OS for netbooks.

Intel's frustration at AMD's apparent attempt to undermine its open source work on Google's operating system also come down to the sheer amount of effort the chip firm has invested in tweaking the platform to make it x86 device ready.

Gefrides explained that since Google's Android development team was relatively small,

it could only focus on one flagship phone every six months or so, leaving other chip and device makers to optimize the OS themselves in terms of having it run efficiently, with optimal battery life.

"The challenging part was getting enough bandwidth to get all of our stuff integrated into the code, but now that's done, the port is done and we're just focusing on how to get the phones out as fast as we can," said Gefrides.

Intel apparently has several teams working on its Android efforts, with Gefrides noting the numbers were in the thousand range. "It's a company wide effort, I can tell you that," he said, noting that the teams spanned everything from the initial Google TV project, to teams working on phones, teams working on tablets, teams working on drivers, validations and other efforts.

Despite the momentum in Android's favor, however, Gefrides said he still felt Intel was a port of choice company, which supported a plethora of operating systems.

"On Linux, baseline driver work is all the same. It's the optimization that's different. We build off our Linux support," he said, adding that Intel had been "a very good open source community player" in terms of driving open source and the Linux environment forward. Whether Intel and Google's views on open source are as transparent as they seem, however, remain debatable.

"If you claim that a project like Android is entirely open source then, yes, Android should be able to run on everything from a PC to a smartphone to a toaster," said Android expert and commentator Russell Holly. Holly went on to say, however, that the point was whether to port the operating system to devices which did not make much sense.

"If AMD was contributing to the Android open source project, that would be one thing, and it wouldn't be fragmenting the platform, but if they're not sharing the work back, there's concern there in so far as fragmentation goes," he said. "If they're not sharing, it defeats the purpose of it being an open source initiative. Using an open source project to create something that is closed source is by definition fragmentation."

AMD did not respond to EE Times' request for comment. ■

TFTs

Rugged TFT-LCD Modules
viewing excellence

- 
- High Reliability
 - Long term support
 - Product range from 4.3" to 19.2"

 **MITSUBISHI
ELECTRIC**
Changes for the Better

semis.info@meg.mee.com · www.mitsubishichips.eu

 **embedded world** 2012
Exhibition & Conference
... it's a smarter world

Halle 1, Stand 163

ARM drives into embedded applications with new module format

By Nick Flaherty

TWO MAJOR EMBEDDED board vendors were pushing the ARM architecture at the SPS/IPC/Drives exhibition but x86 in other formats are still moving forwards, particularly for graphics performance in embedded applications.

The ARM microprocessor architecture is making significant in-roads into the embedded board market with increasing support from Kontron and congatec at this year's SPS/IPC/Drives exhibition. Kontron also took the opportunity to launch a new computer-on-module (COM) format specifically targeted at ARM devices, with initial support from system vendor ADLINK.

The format is aimed at opening up new application areas where power is more important, such as embedded handheld devices and rugged tablets alongside the more established box PCs and HMI systems. By extending the COM usage model to RISC architectures with scalable, modular and out-of-the-box solutions, Kontron sees the new format bridging the gap between current proprietary industrial offerings and offerings from the consumer market that are far less suitable for demanding environments. The deal with Adlink is important for this market as it enables OEMs and system integrators to have a second source for Kontron's newly defined COM.

The new COM format is based on the 314-pin MXM 3.0 connector that is 4.3mm in height so that it can use a cost-efficient horizontal card edge or goldfinger connection. The connector is also available in a shock and vibration proof construction suitable for harsh environments. The standard enables new interfaces specifically for the new ARM and SOC platforms including video outputs such as LVDS and dedicated camera interfaces – a first for a standard COM module. Further on, the format will also allow for the use of DisplayPort 24-bit RGB and HDMI. There are two module footprints to offer flexibility for different mechanical requirements: a short module measuring 82x50mm and a full size module measuring 82x80mm.

“Our strategic entry and massive investment is spearheaded not only by upcoming

product launches, but moreover by a new Computer-on-Modules form factor standard for these new products,” said Dirk Finstel, CTO of Kontron. “This emphasizes our commitment to the standardization of scalable technologies right from the onset. We have been very successful with embedded form factor standardization and particularly with ETX and COM Express standards. Now we have begun to mirror this in the ARM and SOC market segment, which complements that of x86 technology. Compared to the current ARM and SOC approach, which is characterized by full custom designs, customers benefit from the new massively reduced R&D investment costs by using application ready platform solutions, that have not been available in their sectors prior to this standard. And we are very happy to have ADLINK on board to support this standard. This will accelerate its success.”

Rival congatec is also looking to drive ARM devices into the embedded market and deepening its relationship with Freescale Semiconductor. Up until now, congatec has focused exclusively on x86-based Computer-on Modules, but is now adding Freescales i.MX family of ARM controllers to its Qseven modules

COM boards usually integrate all generally available interfaces onto the computer module itself while any special interfaces are implemented on individually-tailored carrier boards. However, this is a problem for existing ARM processors with specialized interfaces designed to suit dedicated applications that are not interchangeable nor scalable. Now the new generation of ARM processors focuses on standard PC interfaces such as USB and PCI Express and so are much more suited to COMs.

The Qseven standard was updated in September 2010 (Revision 1.20) to enable the development of 100% compatible ARM-based modules with these modern interfaces, and expects to have modules based on the Freescale chips in the middle of 2012 with the support software.

“In Freescale, we have found a reliable partner with whom we will be able to meet



Fig. 1: The congatec QMC-B Qseven carrier board.

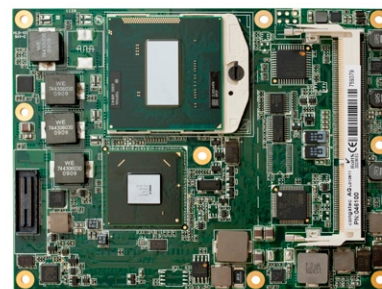

Fig. 2: The congatec TM67 COM express Type 6 module.



Fig. 3: The DSM 96M4361o SBC card for quad-core Intel i7 processors.

the requirements of our customers with regard to operating system support and long-term availability. Thanks to our close cooperation with Freescale, we are now in a position to begin the development of Qseven modules with extremely low levels of power consumption,” said Gerhard Edi, CEO of congatec. “In order to also give our customers a massive time-to-market advantage with this platform, we are investing heavily in software support for the ARM processors.”

At the same time congatec has launched a new mini carrier baseboard for space-critical applications based on the Qseven standard and x86 modules. The baseboard is well suited for fast prototype design and compact, mobile applications. Measuring just 145x95mm, the mini carrier board is

designed to accelerate the evaluation process in the design-in phase to give faster time-to-market. It has interfaces for DisplayPort, HDMI and LVDS 18/24bit graphics together with six USB interfaces and an Ethernet connection. The board also offers additional standard interfaces such as high definition audio and a mini PCI express socket, which can be used for WLAN.

The conga-QMCB is powered by a single 5V DC supply and battery management signalling is fully incorporated, enabling the use of the congatec Smart Battery Manager (conga-SBM2) and making the baseboard a simple solution for mobile systems. The conga-QMCB is designed for use with the new conga-QAF computer module, which is based on AMD Fusion technology, and the conga-QA6, which is based on the current Intel Atom E600 series.

Qseven is not the only focus for Congatec. It has also launched a 95x125mm COM Express Type 6 module with a quad-core Intel Core i7 processor. The conga-TM67 uses the Intel Core i7-2710QE processor (2.1 GHz, 45W, PGA) and the dual-core Core i5-2510E processor (2.5 GHz, 35W, PGA) with up to 8 GByte high-speed dual-channel DDR3 memory (1333 MHz). The Type 6 Pin out allows direct connection to Intel's QM67 Express chipset series and its following generations with VGA and LVDS links and three digital display interfaces, each of which can be configured for DisplayPort (DP), HDMI or DVI. Unlike Type 2 modules, these are no longer multiplexed. Type 6 also provides a PEG (PCI Express Graphics) port enabling connection to other high-performance graphics components and for maximum display support for gaming and medical applications.

The modules also come with new embedded firmware. A board controller comes with an extensive embedded PC feature set that is independent from the x86 processor so that functions such as system monitoring and the I²C bus work faster and more reliably even when the system is in standby mode. But new formats are not necessarily the best way forward. DSM Computer in Munich is expanding its portfolio of PICMG single board computers with an Intel Q67 chip set for second generation Intel Core processors that can be easily expanded with existing standards.

The high-end version of the 96M43610 plugin card can be used with the 3.4GHz quad-core Core i7-2600, Core i5-2400 (3.1 GHz, 6 MB Cache) or dual core i3-2120 (3.3 GHz, 3 MB Cache) processors. The budget version is available with an Intel Pentium G850 processor and two kernels and 3 MB Cache. In accordance with the PICMG standard, the slot CPU features four PCI interfaces with a configurable 16 lane PCI Express link and the board can quickly be expanded with a 338x126 mm Mini PCI Express x1 card.

Kontron has also been focussing on graphics performance and low power with a new embedded Box-PC using AMD's Embedded G-Series processor. The fanless MICROSPACE MPC-p2 is based on the single-core 1.2GHz AMD T44R processor with a Radeon HD6250 graphic unit and DDR3 memory controller. With a 130x99mm footprint, the MPC-p2 provides graphics performance and features that up to now were only possible on systems that were substantially larger and had dedicated graphic cards. The unit supports the latest 3D graphics libraries such as OpenGL 3.2 and DirectX 11 and has hardware acceleration for Flash-based applications so that developers can create graphic-oriented applications in areas such as Digital Signage, media playback, Gaming and POS/POI applications. These can be linked to GSM/UMTS and Wi-Fi networks via extension options in the box. It also supports DirectCompute and OpenCL 1.1 for low power applications such as industrial and medical image processing. ■



MAXIMUM

PRECISION

From a full spectrum of pin receptacles

Regardless of whether your components fly with the Blue Angels or control industrial robots, good design should never be limited by a lack of options. Mill-Max Mfg. Corp. offers hundreds of high-precision receptacle styles with an unprecedented range of options and features:

- 35 pre-tooled contact styles.
- A full selection of 3-, 4- and 6-finger contact designs.
- .008" to .102" (0.20 - 2.59 mm) pin acceptance.
- Accepts round, square and rectangular component leads.
- Styles for soldering, swaging or press-fitting.



Large Variety of Styles



Knock-out Bottom OFF®



Available on Tape and Reel

Mill-Max receptacles. Plug into the simple, reliable connectivity solution.

To view our Design Guide, new product offerings and order free samples, visit

www.mill-max.com/EETE585



Wireless display in a contact lens takes shape

By Nick Flaherty

RESEARCHERS IN FINLAND AND THE US have developed and tested a prototype contact lens that could provide the wearer with a real time hands-free display.

The researchers from the University of Washington and Aalto University, Finland, have constructed a computerised contact lens and demonstrated its safety by testing it on live eyes. At the moment, the contact lens device contains only a single pixel but the researchers see this as a “proof-of-concept” for producing lenses with multiple pixels which, in their hundreds, could be used to display short emails and text messages right into the eye.

The contact lens consists of an antenna to harvest power sent out by an external source, as well as an integrated circuit to store the energy and transfer it to a transparent sapphire chip containing a single blue LED. The device could overlay computer-generated visual information on to the real world and be of use in gaming devices and navigation systems. It could also be linked to

biosensors in the user’s body to provide up-to-date information on glucose or lactate levels.

One major problem the researchers had to overcome was the fact that the human eye, with its minimum focal distance of several centimetres, cannot resolve objects on a contact lens. Any information projected on to the lens would probably appear blurry. To combat this, the researchers incorporated a set of Fresnel lenses into the device; these are much thinner and flatter than conventional bulky lenses, and were used here to focus the projected image on to the retina.

After testing the contact lens in free space, it was fitted to the eye of a rabbit, under the strict guidelines for animal use in the laboratory, to evaluate the effect of wearing the contact lens on the cornea and the body in general. In addition to visualising techniques, a fluorescent dye was added to the eye of the rabbit to test for any abrasion

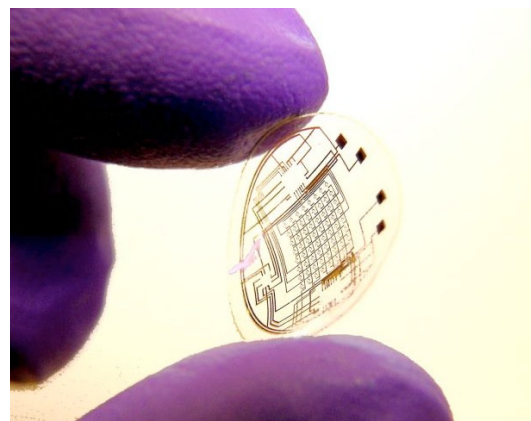

Antenna, control circuitry and interconnects for LED microarrays on a contact lens. Source: Professor Babak A. Parviz, University of Washington.

or thermal burning.

“We need to improve the antenna design and the associated matching network and optimize the transmission frequency to achieve an overall improvement in the range of wireless power transmission,” said Professor Babak Parviz of the Department of Electrical Engineering, University of Washington in Seattle. “Our next goal, however, is to incorporate some predetermined text in the contact lens.” ■

Interdigitated back-contact silicon solar cells show efficiency above 23%

By Julien Happich

IMEC TOGETHER with its silicon photovoltaic industrial affiliation program partners Schott Solar, Total, Photovolttech, GDF-SUEZ, Solland Solar, Kaneka and Dow Corning, have demonstrated an excellent conversion efficiency of 23.3% on interdigitated back-contact (IBC) silicon solar cells.

Interdigitated back contacts are introduced to increase the conversion efficiency of crystalline silicon solar cells and allow for further reduction of the cell thickness, simplification of module fabrication and improved aesthetics of the final solar cell modules. Imec has developed a high-efficiency baseline process for small-area IBC cells within its multi-partner silicon solar cells industrial affiliation program that aims

at increasing the efficiency well above 20% and decreasing the cost of silicon solar cells beyond the current state-of-the-art.

Key aspects of the newly developed small-area (2x2cm²) IBC Si solar cells are the n-type base float-zone (FZ) silicon substrates, a random pyramid texture, a boron diffused emitter, phosphorous diffused front- and back surface fields, a thermally grown silicon dioxide for surface passivation, a SiN single layer anti-reflective coating, lithography based patterning and Aluminum metallization. The realized IBC cells achieve a designated area conversion efficiency of 23.3% (J_{sc} = 41.6 mA, Voc=696 mV, FF=80.4%), certified by ISE-Callabs. Jef Poortmans, director of imec’s photovoltaic R&D program: “We

are delighted to demonstrate these excellent efficiency results on IBC silicon solar cells. They prove the relevance of the IBC technology to our industrial partners. Such high efficiencies on small-area IBC silicon solar cells are a perfect base for further developing a large-area and industrially feasible IBC cell technology at imec.”

“As silicon photovoltaic industrial affiliation program partners of imec we are very happy with this new result”, says Dr. Martin Heming, CEO of SCHOTT Solar. The test result confirms our confidence in imec’s excellent PV R&D capabilities and vision, and it allows us to acquire important know-how and IP as basis for our next generation solar cell products.” ■

TI calls baseband a distraction, but is it?

By Sylvie Barak

WHILE TEXAS INSTRUMENTS pushes forward quickly and aggressively with its OMAP mobile processor, some still wonder whether the firm's "strategic decision" to leave out baseband could come back to bite it. While competing silicon vendors have rushed to integrate baseband onto their chips, TI has shied away from doing so, calling it a mere "distraction" and proclaiming itself glad to no longer be dealing with the connectivity side of the business.

"TI made a strategic decision in 2008 to phase out of the baseband segment and focus on two key Wireless growth areas: OMAP processors and wireless connectivity solutions," said the firm's Director of Strategic Marketing Avner Goren when confronted with the question. "We continue to see proof that this was the right decision, especially as multimedia capabilities are innovating at twice the pace of access technology," he said adding that this was especially true with the sheer pace of innovation in the industry, which he claimed mandated a more discrete approach in order to facilitate faster time-to-market.

Indeed, while new application processors tend to tape out every 9-12 months, new modems are on a slower cycle of 12-18 months, though LTE-Advanced may close the gap a little. Currently, however, this is typically the reason argued for keeping modems and processors on separate dice. On the other hand, mobile chip giant Qualcomm, which does integrate modems onto its Snapdragon processors, has managed to keep pace with its rivals, largely debunking the naysayers.

Instead of integrating its own baseband technology, TI says it supports a range of access technologies which Goren claims allows the firm to integrate its platform with multiple standards from modem suppliers or OEMs with proprietary offerings. Goren added that TI was also pushing chip-to-chip (C2C) interface technology which allows the removal of the modem DDR, purportedly resulting in memory cost and PCB footprint savings.

"We license C2C to major modem vendors, and have partnered with Arteris to widely deploy it," he said, noting that TI had also actively supported the MIPI Alliance's standardization of the Low Latency Interface (LLI), targeted for OMAP 5 integration. While Goren's defense seems solid on the surface, however, analysts in the space have cast doubt over TI's dismissal of baseband. Analyst Will Strauss of Forward Concepts believes Goren is simply "towing the party line," and that while it's certainly true that modems and application processors are on different road maps, integration of the two is a growing trend, especially in terms of cheaper, lower-end phones.

Analyst Jim McGregor of In-Stat agreed, saying that not only would it be cheaper and less of a battery drain, but that Moore's law actually facilitated it. "TI's argument doesn't hold water, because it's not a question of 'if' baseband should be integrated onto the chip, but when," said McGregor adding, "if you're going to be playing in the smartphone market, you need baseband." While it's true that some devices don't necessarily need cellular connectivity today, McGregor posited that as carriers began to think more in the direction of pooled data plans to connect up all of a person's devices, that tenet would become less true.

"There will always be room for a stand-alone OMAP4 or 5, but the number of stand-alone sockets will likely not grow as fast as the integrated pair numbers," agreed Strauss, adding that while the integration trend lay more at the low-end of the smartphone spectrum, Qualcomm's Snapdragon S4 processor with inbuilt LTE modem would more than match up to OMAP5-level capability. "No matter how good OMAP is, there will always be competitors that are in the same "horsepower" category on the same die with the modem," Strauss said.

Interestingly, said Strauss, the "modem being a distraction" was Intel's mantra back when the firm was pushing StrongArm apps processors with a modem acquired from

DSP Communications. When this initiative failed, after a billion dollars or so worth of investment, Intel sold the pair to Marvell for \$600 million - a fraction of the \$1.7 billion it had acquired DSPC for. Seeming to regret that decision several years later, Intel bought Infineon's wireless business for \$1.4 billion last year.

Similarly, Nvidia paid \$367 million for modem chipset maker Icera, A UK based firm with more than 550 patents granted or pending, and product approval from over 50 carriers across the globe, while Renesas acquired Nokia's baseband technology, saying it planned a major thrust into the LTE market. The market for baseband processors is one of the fastest growing segments of the technology industry, worth an estimated \$15 billion a year, according to market watchers. "TI could always partner up with a player like Mediatek, or one of the big Asian carriers who has patents in the area - like Japanese NTT Docomo - but the market for acquisitions is getting pretty slim," said McGregor explaining that after the major acquisition spree last year, most remaining baseband chip makers had been snapped up. "The only one possibly left is Sequans," he said. "Then again, there's going to be some sort of fallout in the mobile market over the next couple of years," said McGregor. "There are currently 24 vendors targeting handsets and there's only really room for about 4. When that consolidation happens, there will be assets up for grabs," he said.

Thus, while TI is certainly moving forward very competitively with Omap, and will be first to market with an A15 chip targeting the high-end where baseband integration is currently less important, the firm may have to re-evaluate as the lower-end integration trend comes more into play. Especially as combo chips like Qualcomm's upcoming 8960 make their way to market sporting not just 3G but TDD FDD LTE, wifi and Bluetooth to boot. "It's certainly going to make things harder for TI, not having baseband going forward, because it is a differentiator for handsets," McGregor concluded. ■

Plastic memory firm partners with organic ink startup

By Peter Clarke

LONG-TIME PLASTIC MEMORY research company Thin Film Electronics ASA has announced a partnership with Polyera, a 2005 startup that supplies organic semiconductor, dielectric, and interfacial materials for the flexible and printed electronics industry.

The two companies have agreed to co-develop gravure-based ink formulations for use in high-throughput printing equipment and will prototype integrated printed system products incorporating Polyera materials, including n-type semiconductors, with Thin-film Addressable Memory.

The agreement calls for Polyera (Skokie, Illinois) to supply commercial quantities for Thin Film (Olso, Norway) and partner manufacturers and to have exclusive rights to ink formulations developed for Thin Film's field of use.

"Polyera's groundbreaking work on n-type organic transistors has paved the way for printed CMOS circuits – more energy-efficient logic circuitry with simpler design. Such printed logic plays a key role when we now are combining our memory technology with other printed components to enable printed systems," said Davor Sutija, CEO of Thin Film Electronics.

Thin Film and PARC, the research

arm of Xerox, used Polyera materials to demonstrate a printed non-volatile memory device addressed with complementary organic circuits, the organic equivalent of CMOS circuitry. The addition of integrated circuits makes the roll-to-roll printed Thinfilm Memory addressable by printable logic.

"We are building an ecosystem and supply chain for a world filled with the Internet of things, where everything is connected via a smart tag.

By engaging with state-of-the-art partners like Polyera, Solvay, who provides the ferroelectric polymer memory material, and InkTec, who recently opened a facility dedicated to manufacturing Thinfilm Memory, we move significantly closer to our goal of enabling fully printed electronics and our memory everywhere

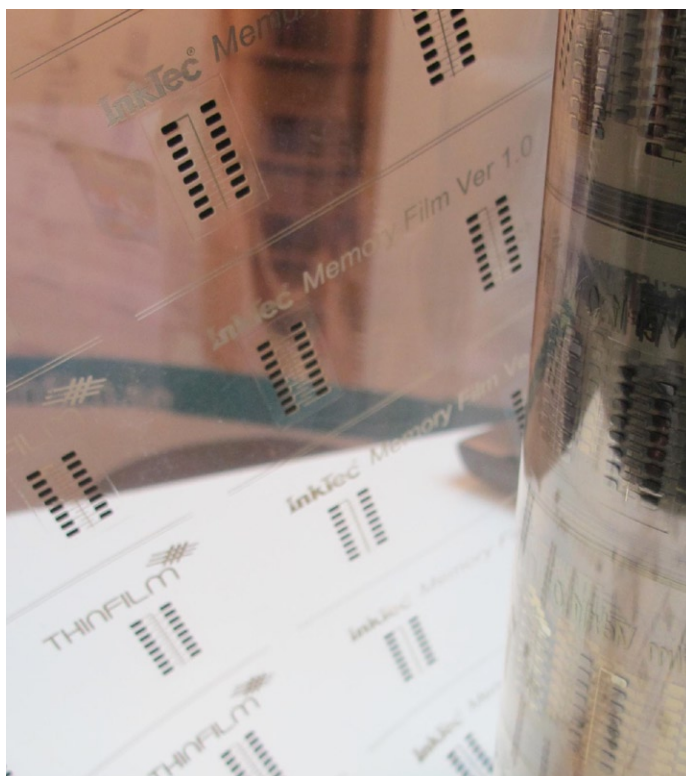

vision," said Sutija.

Thin Film announced in August 2011 that InkTec (Ansan, South Korea) had opened a production facility dedicated to Thin Film's plastic memory. The manufacturing capacity of the facility was not disclosed. ■

Graphene printed via ink-jet, ups mobility

By Peter Clarke

RESEARCHERS FROM the University of Cambridge have reported the ink-jet printing of graphene circuits, thereby demonstrating the suitability of graphene inks for flexible and transparent electronics. The simple use of a graphene-based ink and modified but standard ink-jet printers could bring closer the possibility of flexible, low-cost wearable computing devices, the researchers said.

The ink-jet printing of semiconducting polymer materials is well known for the large-area production of transistors, displays,

photovoltaic devices, organic light emitting diodes (OLEDs). However, the electron mobilities of these materials are still much lower than standard silicon technology. The use of metal oxides and carbon nanotubes has been proposed to improve this but it usually comes at the cost of complexity in terms of adding stabilizer processes. By contrast graphene is a 2-D form of carbon in a single molecular layer that is the world's strongest and most conductive material.

The research team, led by Andrea Ferrari, made the ink by removing microscopic

flakes from a block of graphite and suspending them in N-methylpyrrolidone (NMP). The use of NMP minimizes the "coffee mug ring" effect that occurs when some solvents evaporate.

The team was able to print structures down to 90-nm line widths and below. The liquid-phase exfoliation (LFE) graphene-ink is described as a low-cost way to print thin-film transistors for flexible and transparent electronics. The work was reported in the arXiv publication on condensed matter materials science. ■

NFC solutions are ramping up: not just for secure mobile payment transactions

By Julien Happich

SOME 475 MILLION CONTACTLESS CARDS with microcontrollers are to be delivered in 2011, a 28% increase on the previous year's figure, according to Eurosmart – www.eurosmart.com – and last month's CARTES & Identification exhibition was a good place to pick up the trends.

One could feel that semiconductor chip vendors were a bit more committed to Near Field Communication (NFC), with integrated solutions offering not only the NFC front end, but also some secure elements packaged into their offers.

Mobile network operators (MNOs) may still be undecided as to how they wish to split the cake with banks and merchants, but according to a report from ABI Research, they will provide the majority of NFC-based mobile wallets and the end users will grow to 594 million in 2016, of which Google (with its recently introduced Google Wallet running so far on the company's Nexus S 4G phone) and Apple are expected to take their share.

Of course, there are already numerous non-NFC mobile payment solutions, relying on money transfers and prepaid services such as PayPal's Paycloud where all the transaction coupons or merchants' discounts are recorded and secured on the cloud via a free app. Other alternatives include one-time passwords and audio transaction confirmation, directly from one mobile phone to the other. Today's lack of NFC-enabled payment terminals is still a limiting factor, especially for small merchants who will probably be the last to invest in the new technology.

Others see a market for discrete NFC-enabled tokens or smart cards, outside the operators' captive mobile market, including in healthcare.

Beyond payment applications, smart posters and mobile marketing are the greatest opportunity for service providers and manufacturers of NFC tags; they account for over half of shipments to date and are expected to be the fastest growing segment, accounting for 70% of shipments in 2016, according to ABI Research.



Austriamicrosystems' standalone NFC-enabled microSD card demo board.

At the show, austriamicrosystems demonstrated what the company claims to be the industry's first standalone NFC-enabled microSD card, developed in cooperation with Infineon. To be delivered in a 11x15x1mm form factor, austriamicrosystems' solution relies on an active booster to support NFC data transfers via a micro-antenna design. Thanks to that active booster, the NFC data link is operational even with the microSD card located behind the battery pack, as it is common in today's mobiles, hence OEMs no longer need to accommodate their design with an external NFC antenna embedded into the casing for reliable contactless payment. Commercialized in partnership with memory vendors, this solution could bring NFC capability to all the phones which are equipped with a microSD slot.

Such a standalone NFC solution has the potential to support business models independent from mobile operators or mobile phone manufacturers. The solution combines an Infineon security contactless microcontroller, certified according to the Common Criteria and EMVCo international standards, with austriamicrosystems' AS3922, an advanced active tag analog front end (AFE) IC employing unique active load modulation technology.

The active load modulation concept emulates the tags response through actively transmitting a signal in phase with the reader carrier signal. By boosting the response to the reader it allows for tag functionality in applications with a lot of interference or that require ultra-small form factor antenna.

The AS3922 complies with ISO14443A/B tag emulation with supported data rates up to 106k/bits.

Samsung Electronics unveiled the SENHRN1, a system-in-package (SIP) near field communications (NFC) chip that combines a NFC controller and a secure element storing personal information and security keys with advanced encryption technologies. Dubbed the Secu-NFC chip, the device's 4.3x4.3x1.0mm footprint is the same as a standalone NFC chip and is pin-to-pin compatible, allowing mobile device's designers to immediately adopt the new solution without additional cost, engineering and design efforts. The embedded secure element has a 760 Kilobyte high-density flash memory

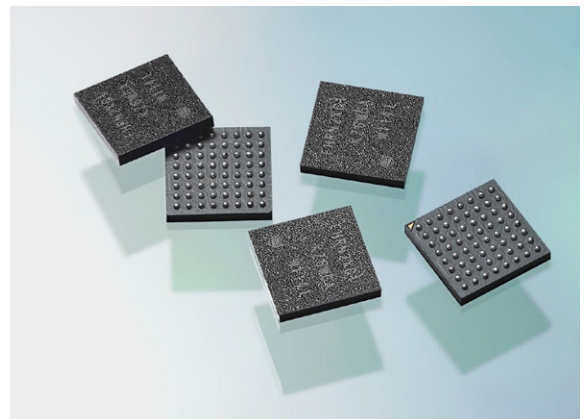

Samsung's SENHRN1 system-in-package secure NFC chip.



HID Global and Sony Corporation's contactless smart card reader platform embeds secure access control and NFC functionalities.

providing users with sufficient capacity to store one's choice of diverse mobile services such as credit card codes, e-money, transportation transaction/payment services, coupon services and more. A battery-off feature enables the chip to remain active for payment transactions even when the mobile device is discharged. Additionally, an embedded single wire protocol interface, allows consumers to enjoy the full breadth of services available by using U-SIM as well as the embedded secure element.

Infineon Technologies released a security chip solution compliant to the open CIPURSE standard as per the specifications of the Open Standard Public Transport (OSPT) Alliance for public transport applications. With a dedicated CIPURSE controller, the company's security chip allows secure access to trains and buses as well as secure, interoperable and flexible automatic fare collection implementations. Infineon also announced CIPURSE compliant NFC (Near Field Communication) secure elements. This allows transport providers to introduce secure ticket purchase and access control via NFC enabled mobile devices.

The company offers CIPURSE functionality for NFC secure elements using Single Wire Protocol (SWP) as well as for embedded Secure Elements (eSE) with Digital Contact Less Bridge (DCLB) interfaces. SWP is the standardized interface between a NFC SIM card and a NFC modem. It can run up to 1.7 Mbit/s and, as standard, it supports all types of contactless transactions. The DCLB interface is a freely available and globally open solution offering a fast (848kbit/s) and transparent connection between an embedded Secure Element and a NFC modem. CIPURSE defines a common feature set that allows to be implemented in different devices such

as smart cards, NFC enabled phones and Secure Access Modules (SAM). It's based on ISO 7816 and features an authentication scheme based on Advanced Encryption Standard AES128.

HID Global and Sony Corporation joined forces to develop a contactless smart card reader platform

that embeds secure access control capabilities and Near Field Communication (NFC) functionality into laptops and other mobile devices. The platform holds a secure element that stores cryptographic keys which secure the authenticity and integrity of user credentials. It supports widely used contactless technologies for applications ranging from physical access control and identity assurance at the desktop to transit-fare, point-of-sale collection and loyalty programs.

The companies have provided the reader platform to the NFC Forum Certification Program as a reference sample to assist in the validation of the Digital Protocol test tools. The reader platform will also be submitted for certification.

The platform supports Sony's FeliCa technology, HID Global's iCLASS and iCLASS SE credentials, MIFARE DESFire EV1 credentials, and other broadly adopted technologies supporting the ISO/IEC 14443 Type A/B contactless smart card standard using the T=CL contactless transmission protocol. The solution also supports the industry-standard PC/SC Version 2.0 specification for the programming interfaces between PC applications, the operating system and smart cards. It is also prepared to further support the proximity features of the next major release of the Microsoft Windows operating system which enable communication between NFC tags and devices (mobile phones or computers) using a tap gesture, as well as the Android operating system for tablet products.

Sony also introduced FeliCa Lite-S, the next generation of FeliCa Lite products planned to reach market next spring. Supporting small antennas, FeliCa Lite-S comes in a smaller chip die and can be used for applications such as single journey and event ticketing, as well as membership, loyalty,

gift, game and ID cards. It is also aimed at NFC Forum type3 tag solutions such as smart posters and handover connections in combination with NFC devices.

In addition to the "Read access control" function of FeliCa Lite, FeliCa Lite-S offers a "Write access control" function by adding a message authentication code (MAC) to prevent any unauthorized access. The combination of data read with MAC code and data write with MAC code makes it possible to carry out streamlined mutual authentication. FeliCa Lite-S's anti-broken transaction functionality prevents incomplete data updates. Even if there is a data error in the chip, it will be detected by the CRC data check code implemented for every data block (16 byte). By adopting the same RF format and backward compatible command set to the existing FeliCa card products, FeliCa Lite-S can be used with the same reader and development infrastructure, for example FeliCa Port, NFC reader and SDK for NFC/FeliCa. Just before Cartes, Sony had opened up the healthcare market to mobile-based NFC applications with its NFC Healthcare Library, an application development software designed to facilitate data exchange between NFC/FeliCa compatible smart phones and NFC-enabled healthcare devices, freely downloadable from the Sony Global FeliCa website.

Maxim Integrated Products exhibited its security devices and a first for the analogue components company, a full reference design for a secure NFC-enabled point-of-sale (POS) terminal. Dubbed JIBEPOS, the PCI-ready reference design comes complete



The NFC-enabled POS terminal reference design from Maxim, complete with its casing.

Factory Hardened

Our signal-chain solutions withstand the toughest conditions

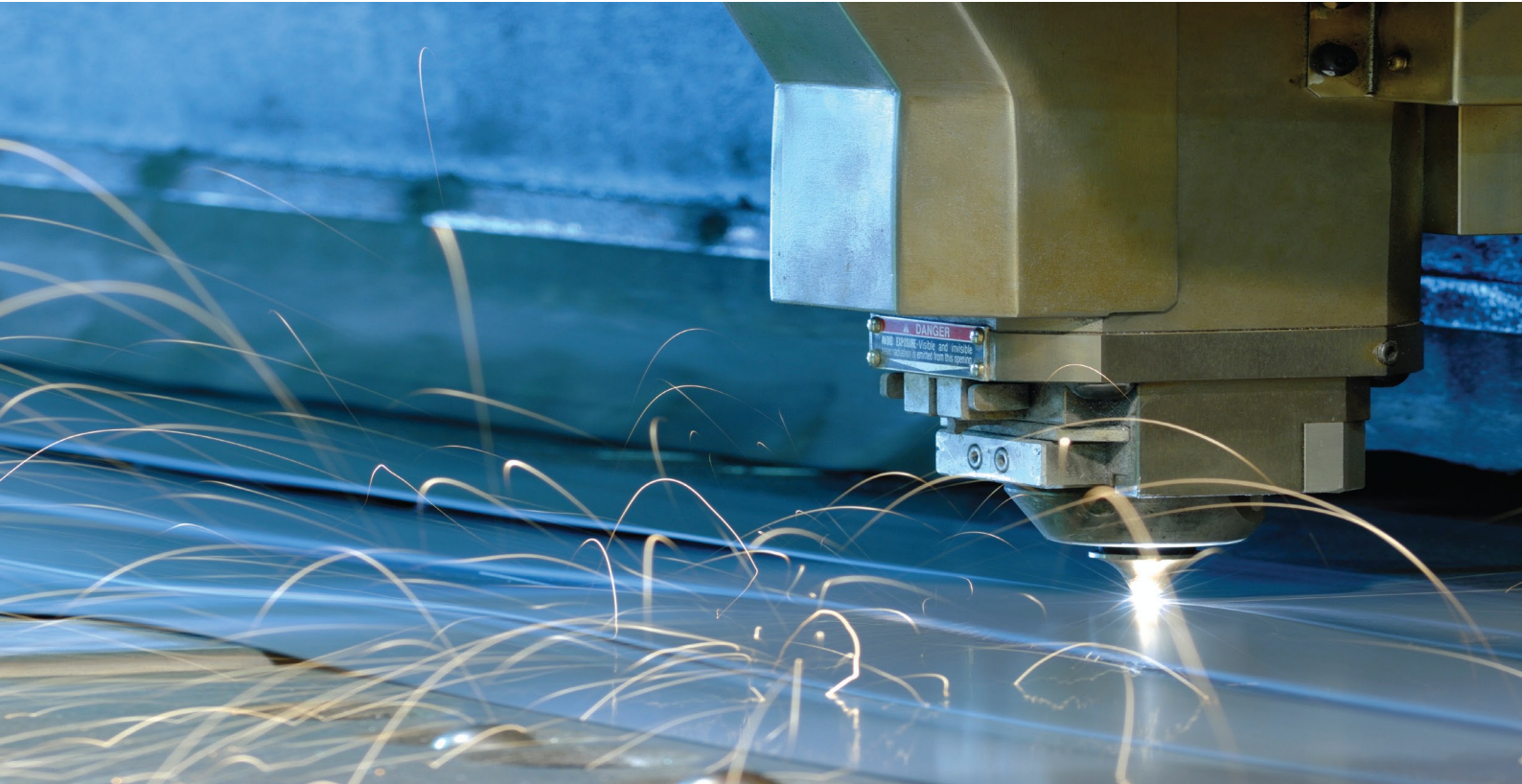

To withstand anything, you can't just use anything. Maxim's industrial signal-chain solutions are built from the ground up to withstand extreme temperatures and destructive electrical events. Industry-leading ESD protection, latchup immunity, and fault tolerance are built in. So you get a smaller, simpler solution that is tough enough for the factory floor.

Get the Toughest Signal-Chain Solutions

- Data interfaces offer up to $\pm 35\text{kV}$ ESD protection to prevent damage to industrial fieldbuses
- High-voltage op amps withstand $\pm 8\text{kV}$ ESD and increase latchup immunity
- 72V analog multiplexers eliminate external protection circuitry
- Multichannel, simultaneous-sampling delta-sigma ADCs provide redundant paths for increased fault tolerance

See for yourself. Order free samples of these products today.

www.maxim-ic.com/factory-hardened

MAXIM
INNOVATION DELIVERED®

MAXIM
DIRECT

www.maxim-ic.com/shop

AVNET
MEMEC

www.avnet-memec.eu

SILICA
An Avnet Company

www.silica.com

Digi-Key
ELECTRONICS

www.digikey.com/maxim

MOUSER
ELECTRONICS

<http://eu.mouser.com/maximic>

with all of the necessary components for designers to build their own terminal, to both dramatically speed up time to market and pass PCI PTS 3.1 standards.

The reference design includes PCB and patented secure-keypad layouts, plus an optimized BOM, certified EMV-L1 library, PCI-PTS-compliant secure Linux operating system, and a security handbook to adapt the design to a unique enclosure. The terminal itself comes with a 3.5" TFT colour haptic touch-screen display, a secure magnetic card reader, an NFC contactless reader, and a high-speed printer. The entire terminal is powered by the company's MAX32590, a secure SoC running a 384MHz 32-bit ARM9 core with extensive connectivity options.

The company is also working on a secure MCU, dubbed Londa, which would secure the display only when required (i.e. for entering a PIN or reading out the bill). In a pass-through mode, the Londa chip would let merchants push customized information through the terminal's screen, while in a trusted mode, the interface would be locked so that only certified payment transactions may be performed.

Effectively, this would enable POS terminal designers to use any non-certified application processor for the graphics display, eventually driving the BOM down.

Maxim also showcased NFC smart tags for applications ranging from access control, electronic cash, or poster read-out (bringing up a URL from the tag's on-chip memory to the phone's web browser).

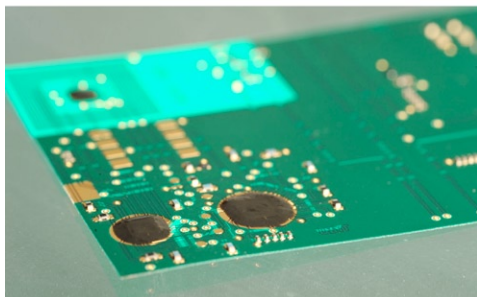
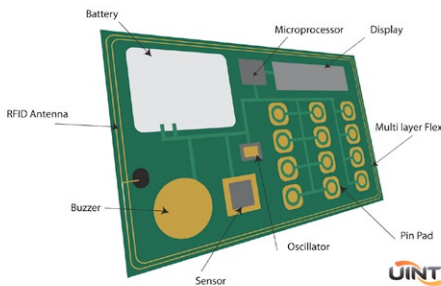

UINT's thin, flexible and independent circuit blocks embedded into a credit card footprint (left). A set of interactive smart cards, including the SoundLights card, a gaming card and a health care card (right).



A multi-card application platform about 5mm thick and the size of a credit card, La Carte was demonstrated at STMicroelectronics' booth.

Now, even in a world of NFC-enabled mobiles, the handset may not be consumers' favourite support for their multi-card applications, still too bulky and too expensive for what could be a low-cost and lightweight mass-transit token, free from mobile operators' control. This is the bet from Famoco, a Beijing-based software company specialized in designing and building smart card software and secure mobile application.

The company was showcasing prototypes of what will be launched in spring next year as "La Carte": a multi-card application platform about 5mm thick and the size of a credit card.

Demonstrated at STMicroelectronics' booth, La Carte will be running on the company's STM32 32-bit Flash microcontroller and will use STMicroelectronics' NFC technology (ST21 NFCA) associated to an external secure element.

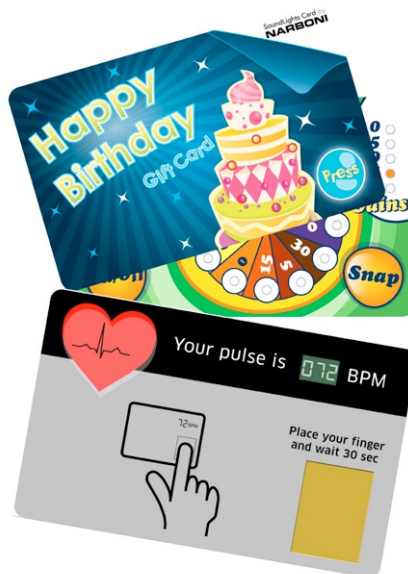

Famoco could sell La Carte to third parties but may also offer the reference design to OEMs for mass production and commercialization to banks, transport operators and merchants willing to bundle their services.

Through the platform's touch-screen, users could select from coupons, pre-paid services, or various payment options before

entering their PIN for a secured transaction. The platform relies on Famoco's dynamic NFC MIDlet, an application engine that can "pull" new service interfaces or updates from the company's NFCme Server, a high performance J2EE Web App which can be integrated into a third-party server.

An exception to this NFC-only review, one of the most interesting smart card developers on the show was young company UINT - www.uint.fr, founded in 2008 around former executives from nCryptone. UINT operates as a technology integrator on smart cards, offering to develop and sell thin, flexible and independent circuit blocks embedded into the credit card footprint.

The company offers a full array of customizable elements, ranging from thin film colour or monochromatic displays and flexible batteries, to embedded memory, pressure, temperature or fingerprint sensors, sound transducers, LEDs and even MEMS devices. The ISO format (54x86x0.8mm) cards can be customized and printed on demand, while retaining full functionality of an ISO magnetic card or an NFC-enabled token.

Several cards were on display, one of them, the SoundLights Card launched by Narboni, lights up while playing music at the press of a button. UINT also developed a card embedding an accelerometer and a speaker to assist healthcare professionals in giving cardiac massages at the correct amplitude and pulsation rate.

The card could even be distributed outside the healthcare industry. Similar cards could be designed for health and fitness applications, logging the pulse rate or functioning as a pedometer, other cards could be designed for temperature logging with time capture in food transport applications. The possibilities are endless. ■

NFC-enabled phones as a tool for brand protection

By Hamed Sanogo and Christophe Tremlet

COUNTERFEITING HAS GROWN tremendously over the last decade. According to government data, officials seized \$188 million worth of counterfeited merchandise in the U.S. in 2010. Not only is the overall value of counterfeited goods increasing, but counterfeiting is penetrating more and more sectors.

Among these, luxury goods are a target of choice, as their value heavily relies on the brand itself. Counterfeiting has an impact on the brand owner, as it creates revenue loss; but even worse, it damages the image of the brand. The consumer is also a victim, especially when there is no way to check whether a luxury-branded item is genuine or not. Several anti-counterfeiting solutions exist. Of these, advanced printing techniques

adopted RFID technology, where an RFID tag is attached to the item to be protected.

At any moment, the tag can be checked through an appropriate reader. If the data read from the tag matches with the expected data, the item is authenticated and recognized as genuine.

Risks, drawbacks, and weaknesses of a UID-based solution

Most RFID solutions deployed today are based on a unique serial number or "UID". The core principle of UID-based solutions is that each tag contains a unique number. When read from the RFID tag, this number is checked by the authentication system against its records. If the number is part of the database, it is considered a valid number

and the good is authenticated. This provides a first level of protection, but the weakness of such systems is that they are sensitive to man-in-the-middle (MITM) attacks. With an off-the-shelf reader, an attacker can intercept a serial number and record it. Once the number is recorded, the attacker can easily forge a fake tag. The same serial number is programmed in a new off-the-shelf tag, and the tag is cloned for reuse.

System integrators have implemented countermeasures to mitigate these kind of attacks. For instance, the reading infrastructure might check if a given number has already been used or if the geographic location matches the one expected.

While these countermeasures are effective, they have two drawbacks: they increase the complexity of the infrastructure, and they do not allow the end customer to check that the good is genuine. An advanced infrastructure can be deployed in warehouses, but one can hardly imagine it installed at a

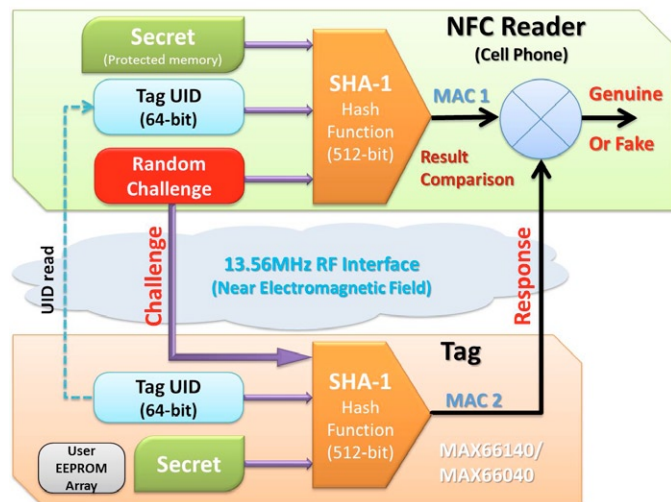
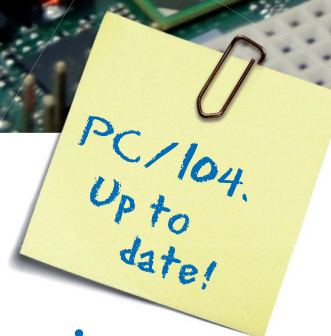

Fig. 1: SHA-1-based challenge-response authentication principle.

are still the most prevalent, which include holograms, unique ID numbers, and tamper-proof labels. To answer the increasing level of threats, some companies have also

Hamed M. Sanogo is an Executive Business Manager at Maxim Integrated Products – Hamed can be reached at hamed.sanogo@maxim-ic.com Christophe Tremlet is the Security Marketing Segment Manager at Maxim Integrated Products. He can be reached at Christophe.Tremlet@maxim-ic.com



» Keep in mind! «

- » **Compact!**
Only the size of 90x96 mm
- » **Flexibility!**
Ready for application development – just start!



MICROSPACE® MSM-e0

PC/104-Plus™ SBC with the new AMD™ embedded G-Series. Full ISA support!

PC/104. UP TO DATE!

Learn more:
Info-Hotline:
+ 49 (0) 8165 77 777
Email: info@kontron.com
kontron.com/PC104

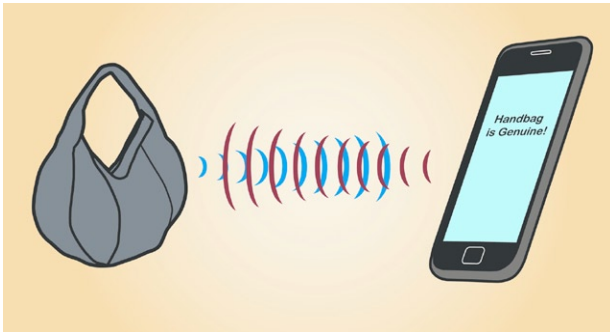

cellular phone comes near the vicinity of the luxury good equipped with a SHA-1-enabled tag, the following sequences of events take place.

A near electromagnetic field establishes between the phone and the item, the electromagnetic field energizes and wakes up the tag and the handset establishes a connection with the tag via ISO 14443/15693

protocol. The handset reads out the tag's UID and the handset's API generates a random challenge and sends it to the tag. The tag computes a SHA-1 message authentication code (MAC) with its UID, secret, and the random challenge received.

The handset locally computes its own MAC with its locally stored secret, random challenge (the same one which was sent to the tag), and the UID read from the tag. Then it compares the value of its MAC against the one computed by the tag.

If the two MACs match, the tag is authenticated. The handset might then read additional data from the tag's memory, such as the date and place of manufacture and the lot number.

This essentially means that the product is genuine. However if the MACs do not match, the item is deemed fake, a knockoff, or counterfeit.

Benefits of the challenge-response

While manufacturers have been relatively successful in eliminating electronic device counterfeits (mainly because they have power and electronics circuits on board in applications where contact is made), this success has not been seen with cloned apparels, medicines/drugs, designer handbags, shoes and sunglasses, as well as with knock-off perfume and wine bottles, just to name a few. The lack of a proper solution to the counterfeit epidemic has led to a continuously growing market for counterfeits, replicas, and imitation goods, which most likely do not meet the manufacturing standard or the safety and protection provided by their genuine counterparts.

A strong crypto hash technology like SHA-1, combined with NFC technology, makes a strong anti-counterfeiting/cloning tool. It is nonreversible (as it is computationally infeasible to determine the input corresponding to a MAC), collision-resistant (since it is impractical to find more than one

input message that produces a given MAC), and has a high avalanche effect (as any change in input produces significant change in MAC result). Buying a luxury good with peace in mind can become an easy endeavor. Just a slight scan over the items and the user knows within a few seconds whether the object is genuine. Another key benefit of this technology is the elimination of counterfeit drugs and perfumes/fragrances, which can be very hazardous to public health. These types of counterfeits have an additional negative impact on manufacturers in terms of sales revenue and a customer loyalty decline, due to imitations that do not produce the authentic products' claimed effects.

In addition to enabling product authentication by end customers, challenge-response authentication also dramatically simplifies the RFID infrastructure for both the manufacturer and the supply chain. This is especially a relief for the latter; because of UID RFID weaknesses, the supply chain has had to implement countermeasures in its infrastructure. This included combining the UID with a geographical location, checking that a number is not used twice, and so on.

As opposed to UID-based solutions, in challenge-response-based implementations, security is self-contained in the tag-enabling product's authenticity verification. This is accomplished with a simple, lightweight reader that does not need to be sustained by a sophisticated infrastructure.

Maxim's recently introduced MAX66140/MAX66040 chips combine 1024 bits of user EEPROM, 128 bits of user and control registers, a 64-bit UID, one 64-bit secret, a 512-bit SHA-1 engine, and a 13.56MHz ISO 14443B/15693 RF interface. These ICs come in a variety of packaging, including key fob, inlays, ISO cards, wound coil, bare die, and custom packaging. The strength of the MAX66140/MAX66040 tag in combating counterfeiting resides in the size of the SHA-1 engine (512 bits), the cost, and SHA-1 engine's fast computation time.

With the ubiquity of NFC-enabled cellular phones and the boost that this has added to the NFC ecosystem, an imminent anti-cloning solution has just been created.

By hiding a SHA-1-enabled tag on their products, and by making APIs and software applications available to all cellular phone users, manufacturers can get end users to help protect their brands against counterfeits. ■

Fig. 2: Counterfeit identification made easy.

final retailer. Furthermore, it is desirable for buyers to be able to independently identify fake objects. Considering the fact that security is at least partly implemented in the infrastructure, this seems hardly achievable.

We will see how challenge-response-based tags can allow buyers to detect counterfeited goods themselves thanks to near-field communication (NFC) technology, thus overcoming the current limitations of the UID-based tag technology.

Description of the challenge-response principle

In its simple form, the challenge-response principle, also known as challenge-response authentication, is a hand-shaking protocol in which one party (the NFC phone) presents a question ("challenge"), and another party (the NFC tag) must provide a valid answer ("response") to be authenticated. Using challenge-response to identify a friend or foe status of connecting devices has been in practice in the wired world for years. It is commonly used in printer cartridge and medical consumables, notebook computer battery packs, and power adapters.

With the NFC-based challenge-response authentication principle, anyone will be able to use an NFC-enabled cellular phone to scan a luxury good to check for authenticity. Manufacturers would only need to hide a SHA-1-based NFC tag on the luxury good (e.g., embed a tag IC in the quirk of the rare wine bottle).

The NFC reader will then be able to identify the item as genuine after it has been authenticated as such. The major components of an NFC authentication scheme include the random challenge, the tag's UID, and the secret. The secret is programmed in the tag's protected memory and is known by the cellular phone's application software API. A strong key management is required to keep the system from being compromised. As shown in Figure 1, when the NFC-based

Designing a compact vehicle tracking platform

By Michael Parker

1.5 MILLION CAR RELATED THEFTS were recorded in 2007-2008 according to the UK home office statistics. To help owners of vehicles not to be among the theft victims, Scorpion Automotive developed a new vehicle tracking platform.

With the support of Rutronik, the manufacturer now successfully offers a low-price technologically advanced system. For the new vehicle tracking platform, Scorpion had clear objectives: it should be a MCU based low-power system that is compact and robust, on a budget that would compete aggressively in the after-market automotive arena. With these specifications, they approached Rutronik to cost up and recommend components solution.

The core components that Rutronik had to select were a GSM and a GPS module and the microcontroller. For the GSM slot, Rutronik chose the GE864-QUAD module from Telit. "It is a small quad band, low power module with an extended temperature range, that was proven to be very reliable and competitive", explains Lee Trueman, Field Application Engineer at Rutronik. "Above that, its BGA low profile package reduces the cost of production and PCB assembly significantly." For GPS capability, Rutronik proposed a Fastrax UP500 GPS receiver module.

With its embedded GPS antenna, the module offers high performance navigation, allows easy integration to the host system and offers a compact, capable and cost effective solution. Its good acquisition sensitivity enables fast position fix in harsh urban canyons or blocking environments, removing the need for an external antenna.

The power supply and serial data is all that is required to make the receiver operational. The module also supports dedicated control commands for external control of the operating state. Built-in PCB-mounting flanges and standard 2.54mm I/O-pin pitch enable easy and reliable mounting on the host PCB.

Today, Fastrax UP501 is the successor of the UP500. It offers further improved sensitivity due to the MT3329 chipset with -148

dBm (Cold Start Acquisition) and -165 dBm (Navigation). Therefore, the UP501 can have a fix even indoors when necessary. Compared to its predecessor, it scores with an improved power consumption of 75mW at



POWER

smarter, faster, smaller

At CUI, our approach is to develop smarter, faster, smaller power modules. Whether it's an embedded ac-dc power supply, a board level dc-dc converter, or a level V external adapter, we continuously strive to keep our power line, that ranges from 0.25 W to 2400 W, ahead of the curve.

Check out the latest addition to CUI's power line:
720 W Novum Intermediate Bus Converter



NQB 1/4 Brick IBC Converter

Highlights

- Industry leading power density
- Driven by CUI's patented Solus Power Topology™
- DOSA compliant pin-out

Specifications

- 720 W / 60 A output
- 1/4 brick package
- 36-60 Vdc input range
- Greater than 96% efficiency

solus
A CUI TOPOLOGY

cui.com/power

CUI INC®

Michael Parker is product manager at Rutronik UK Ltd - www.rutronik.it

3.0V and a tiny form factor of 22x22x8mm. The microcontroller was supported by Microchip.

The manufacturer proposed a 16-bit high performance MCU with Flash/Ram with an extended temperature range.

While all relevant data such as application notes, datasheets or user guides were provided to Scorpion Automotive, Rutronik also supplied samples and Telit's evaluation kit, together with advice on software and components testing. The Telit support, based in Italy, validated Scorpion's schematic and Gerber files to ensure that the design was efficient and compliant to wireless and automotive approvals. Within just a few weeks, the parts proposed by Rutronik were approved on Scorpion's board. Soon afterwards, Rutronik supplied the first production volume for field trials which once completed successfully, enabled Scorpion to ramp up production.

Scorpion Track offers insurance-approved

pin-point GPS tracking in both a stolen vehicle scenario or simply via 24 h web based access worldwide. The positions of the vehicles are plotted on a full road map with terrain option. Upon illegal movement detection, the tracking system discretely notifies the Scorpion international control centre of a possible theft.

The monitoring staff will contact the car owner with details about the vehicle movement in order to confirm a theft in line with current Police legislation and procedures. Any alarmed vehicle is tracked until the recovery or a false alarm has been confirmed.

Once a theft has been confirmed and a crime reference number has been obtained from the Police, Scorpion Track operatives will liaise with the Police in order to recover



the vehicle.

Upon recovery, the Scorpion Track operator will arrange the return of the vehicle. Scorpion Track is fully approved to the Thatcham TQA standard for Stolen Vehicle Recovery systems and will therefore cater for all insurance requirements.

When Telit came out with the GE864-QUAD-V2, a cost reduced light version of the GE864-QUAD, the adaption into customers' design was easily made, saving further investments. ■

Multimodal and simultaneous biometric authentication goes mobile

By Julien Happich

SWISS COMPANY BIOMETRY has launched a multimodal and simultaneous biometric authentication technology that can run on multiple platforms, including camera phones and webcam-equipped laptop computers. The MobiComBiom (Mobile Communication Biometrics) software guarantees unique user authentication by requesting four authentication processes, biometric face recognition (through the mobile's built-in camera), biometric voice recognition, recognition of biometric lip movement, and word recognition, simultaneously with randomly generated numerals (random challenge response or one-time password) for the user to pronounce.

By pressing a specific "soft button" on the cell phone (e.g., numerals 1 and 3 are pressed simultaneously), the MobiComBiom authentication process is started. With it, four randomly selected numerals appear successively on the cell phone display. Similar to video telephony, the user speaks these numerals. The video and audio data is

then securely transmitted to the provider (so-called trust center), where every numeral is converted into files (so-called templates). These are compared to the reference data that was previously learned by the user for the numerals 0, 1, 2, ... to 9. If the data matches, the user of the cell phone is uniquely authenticated. The software cuts out cybercrime, including modification Trojans, by fixing the transaction data with this four-factor biometric verification.

The software is very simple to implement and yet very secure. Users can define the level of trust for various applications (IT access, web services, payment credentials). After authentication, the trust level reaches 100% for a period of 10 minutes. After that, the percentage rate successively lapses to

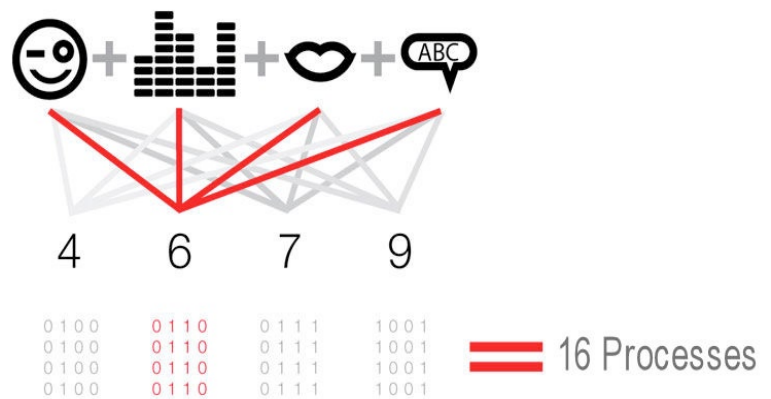

lower percentage and allowed payment amounts in order to allow for the chronologically increasing risk of theft. With every telephone call, the voice is biometrically authenticated and the trust level is increased with a match.

However, the multimodal, simultaneous biometric authentication with a random challenge response will prevent replay attacks. It can operate in a noisy or a low light setting if the user decides to increase the trust level solely through biometric face recognition or through voice recognition, respectively. ■

SPECIAL FOCUS: IDENTIFICATION

Re-inventing smart cards *with agnostic PKI middleware*

A provider of agnostic PKI middleware, Charismathics announced iEnigma for BlackBerry, porting the smart phone application to the large market of mobile handsets of the Canadian phone maker RIM. iEnigma fully turns the smart phone into a smart card and avoids investments in smart card readers, expensive USB keys or other hardware by a simple Bluetooth connection. It ensures security for both the computer, and also supports the remote use of the applications that reside on the smart phone itself. The middleware

also extends the use of Identity Management Systems to full hands-free operations of the user and allows for much higher flexibility for authentication setups. With optional extensions such as secure microSD cards or NFC connectors the application provides full flexibility for any kind or size of IT environment.

Charismathics

www.charismathics.com



Automotive MCU increases in-vehicle security *enables tamper-proof ECUs against motor tuning*

The 32-bit MCUs of the AUDDO MAX family from Infineon Technologies extend the tamper-proofing of electronic control units (ECU) and protect against tuning, for example. AUDDO MAX SHE enables automotive manufacturers to ensure the integrity of their ECUs and to guard better against exposure to liability claims. Three products of the AUDDO MAX family come with SHE (Secure Hardware Extension) functionality. The AUDDO MAX SHE monolithically integrates a secure keystore which cannot be read without access authorization. Infineon's integrated solution has the advantage over the version using external security chips that the communication does not run via interceptable external bus systems.



In addition, SHE has a cryptographic module which encrypts access codes with up to 128 bits. It is complemented by an array of hardware functions which, for example, prevent the application code from being illegitimately read and altered, or identify ECUs in the system network. These are important functions for tamper-proofing control units and protecting them against theft. Even if such an ECU were to be fitted in another identical vehicle, its engine performance characteristics could not be changed: the cryptographic individual key of an ECU has to match all the cryptographic keys within the ECU network of a vehicle. And that key is safely stored in the SHE.

Infineon Technologies

www.infineon.com

13.56MHz RFID keys and cards *support both ISO 14443B or ISO 15693 protocols*

The MAX66000/020/040/100/120/140 contactless RFID product family leverages Maxim Integrated Products' 1-Wire secure authentication ICs, which protect intellectual property in embedded systems. With a 13.56MHz interface, these secure keys come packaged in a laminated plastic key fob or ISO thin card format and are available in either the ISO 14443B or ISO 15693 HF protocol. Each protocol family offers three products: 64-bit ROM ID only (MAX66000/MAX66100), ROM ID plus 1K-bit EEPROM (MAX66020/MAX66120), or ROM ID plus 1K-bit EEPROM and SHA-1 authentication (MAX66040/MAX66140). Custom form

factors are also available. The MAX66040 and MAX66140 employ the secure hash algorithm (SHA-1), an ISO standard that is publicly available and has been thoroughly tested in the marketplace. It is designed to maintain the integrity of the stored data so that one can verify the authenticity of any credential. Maxim's RF keys and cards are custom programmable to match the requirements of new and existing tag populations. They work with most 13.56MHz readers on the market.

Maxim Integrated Products

www.maxim-ic.com/rfid



easy care



easy preparation



easy handling

Sensor solutions from Cherry

require neither experience nor finesse.

Because they're pre-configured – and ready to use: complete with screw threads, clip technology, connector pins, etc. Standard types and connectors to enable seamless installation. Deliverable at short notice, they fully meet today's

ambient condition requirements. Sounds too

good to be true? Convince yourself!

www.cherry.de • switches@cherry.de

Tel. +49 (9643)18-0



Fingerprint swipe sensor

with 508dpi resolution for mobile applications

Fingerprint Cards' FPC1080A swipe sensor is now available for ordering in volume. The small sensor uses FPC's patented sens-

a joystick or a touchpad. These elements and many more functions make the robust FPC1080A suitable for sev-

eral types of mobile high-volume products such as mobile phones, tablets, remote controls and USB keys. In connection with the launch of the FPC1080A, several associated products will be available for

ing technology and delivers 3D image quality, with a resolution of 508 dpi. In addition to intelligent image management, the sensor includes integrated hardware support for navigation, enabling the sensor to be used as

ordering, such as demonstration units, development units with PC connections and prototype cards.

Fingerprint Cards

www.fingerprints.com



Security processing unit brings AES

based cryptography to mobile applications

Intrinsic-ID's Confidentio is a securely integrated and optimized IP solution that combines the company's flagship product Quiddikey for secret key storage with a FIPS-197 compliant AES cryptographic IP core. Confidentio leverages the superior security and anti-tamper characteristics of Quiddikey in a pre-integrated security processing unit (SPU) IP that can be easily embedded in a mobile application processor, a Secure Digital (SD-) card or SmartCard. It offers security processing for content protection, secure payment protection, secure communication channels and secure storage (local memory encryption and/or cloud storage).

describes as the world's first and only encryption module that has built-in key storage functionality without requiring embedded non-volatile memory, resulting in an extremely small silicon footprint. This IP solution is available for licensing as synthesized RTL (netlist) for hardware implementations, including in the smallest technology nodes (40nm and below) on Microsemi's SmartFusion customizable system-on-chip (cSoC), as well as ProASIC3, IGLOO and Fusion FPGAs. It is also available in software version (ported on various embedded CPUs)

Intrinsic-ID

www.intrinsic-id.com

Solid-state drive

features self-encryption for laptops and desktops

Micron Technology introduced the C400 SED (self-encrypting drive), based on the Trusted Computing Group (TCG) Opal specifications. The C400 SED's encryption capabilities are delivered through a hardware-based, AES-256-bit encryption engine and advanced security firmware. Micron's firmware is designed to comply with the open TCG Opal specification, an industry standard that provides a verifiable path for companies who need to prove they're compliant with tough data security regulations when devices or drives are lost or stolen. Like all hardware-encryption, the drive works in conjunction with an encryption management system. Micron's C400 SED solution was built in partnership with leading encryption management provider Wave Systems. Wave's Embassy management software provides policy-based access controls, comprehensive reporting, directory services integration and end-user access recovery that allows IT to

cost-effectively implement and administer endpoint encryption. Importantly, Wave's management software gives IT confidence that data is protected in the event that a computer—or the drive itself—is lost or stolen.

The C400's encryption key is protected within drive hardware, separate from the host. User authentication is performed by the drive prior to starting the operating system, ensuring independence from the operating system. What's more, all the encryption is performed inside the SSD's controller, ensuring no system performance degradation. The C400 SED SSD is available in 128-, 256-, and 512GB capacities, a SATA 6Gb/s interface, and 2.5 and 1.8-inch form factors. The drive's sophisticated NAND management delivers sequential read and write speeds of up to 500 MB/s and 260 MB/s respectively.

Micron Technology

www.micron.com

Low frequency RFID reader

embedded in single-package microcontroller

Atmel has launched an AVR microcontroller (MCU) with a RFID reader block and 16kBytes of in-system self-programmable Flash. Available in a 5x7mm QFN package



and operating in the low-frequency (LF) range at 100-150kHz, the ATA5505 is suitable for all kinds of LF Amplitude Shift Keying (ASK) RFID readers and programmers for access control, industrial automation and animal identification applications. The ATA5505 makes building a complete reader an easy process requiring just a few external components and an antenna coil. Using the new device eliminates the need for expensive discrete components such as crystals, which are currently required with competitors' 2-chip RFID solutions. The required PCB footprint is also smaller than with competing solutions where the MCU and RFID reader are located in two different packages. The Atmel AVR MCU

provides 512Byte SRAM, 512Byte EEPROM, 16 general-purpose I/O lines, 32 general-purpose working registers, one 8-bit timer/counter with compare modes, one 8-bit high-speed timer/counter, a universal serial interface (USI), a LIN controller, internal and external interrupts, a 11-channel 10-bit A/D converter, programmable watchdog timer with internal oscillator and three software-selectable power-saving modes. By executing powerful instructions in a single clock cycle, the device achieves throughputs approaching 1MIPS per MHz, balancing power consumption and processing speed.

Atmel

www.atmel.com

Low-power fingerprint sensor

targets mobile biometric devices

The U.are.U 5100 fingerprint module is an optical, touch-style fingerprint sensor aimed at handheld ID terminals and other devices used in Civil ID applications such as voting, benefits-checking and micro-finance. It draws less than 110mA in scanning mode and around 50mA in idle mode. The 52x31.4x15.8mm unit enables applications fine-grained control over the operations of the biometric sensor and user-feedback lights, extending the battery life of mobile devices. Its ergonomic blue "landing lights" help guide the user for simple, accurate fingerprint scans; applications



can also use red and green status lights built into the sensor itself to provide immediate feedback without the need for a separate display screen. The device is designed to meet and exceed the FIPS 201 Personal Identity Verification (PIV) Image Quality Specification and produces 500dpi and 1000dpi fingerprint images in ANSI and ISO/IEC standard formats, at an 8-bit grayscale resolution. Built for use in demanding environments, the U.are.U 5100 features a hard glass, IP64-rated imaging surface that is sealed against dust and liquids.

Digital Persona

www.digitalpersona.com

Anti-counterfeiting NFC chip

protects high-end consumer products

French chip designer Inside Secure has developed a Security Module with a self-powered NFC radio interface to protect products from counterfeiters and cloners. The VaultIC150, a low-cost and compact turnkey NFC-based security solution designed for embedding into high-end consumer or luxury products that are often targeted by counterfeiters and cloners.

The chip allows consumers with NFC-enabled mobile phones to verify that the product is an original and not a counterfeit.

The VaultIC150 solution's wireless NFC interface has a range of several centimetres and is available in several antenna form factors. This means that the chip can be deeply embedded into the product

without leaving any visible trace. The security engine employs elliptic-curve mutual authentication, a highly-secure and efficient method of protecting the products with banking-level security. The security engine was designed to meet the constraints of the EAL4+ and FIPS 140-2 L3 certification. On the chip are voltage, frequency, and temperature detectors, illegal code execution prevention, tampering monitors and protection against side-channel attacks and probing. Complementing the NFC interface is a simple software application on the user's mobile phone that Inside Secure provides to the product manufacturers.

Inside Secure

www.insidesecond.com



OLAE+

Organic and Large Area Electronics European Competition for Collaborative R&D Funding

OLAE + is a transnational call for collaborative research and development proposals under the European Commission's ERA-NET Plus scheme. ERA-NET Plus schemes are aimed at developing and strengthening the coordination of national research activities with enhanced trans-national funding by "topping up" with Community funds as an incentive from the Commission.

The competition is open to participants from Austria, Catalonia, Flanders, Germany, Israel, Poland, Sweden and the UK (the participating countries/regions).

Organic & Large Area Electronics (also known as plastic electronics, printed electronics or organic electronics) allows electronic circuits, devices and products to be produced using relatively low cost printing processes onto any surface, whether rigid or flexible, and over large areas. It will lead to the creation of whole new generations of products such as conformable and rollable displays, large area efficient lighting, low cost solar cells, low-cost RFIDs and memories, flexible and environmental friendly batteries, and others.

Proposals are sought to stimulate the technology and business relationships within the European OLAE community, removing barriers to industrialisation. A wide range of technical topics are in scope for the competition and full details can be found on www.olaepplus.eu

OLAE+ is funded through the European Commission and participating member countries and regions, Austria, Catalonia, Flanders, Germany, Israel, Poland, Sweden and the UK

Bringing P-Cap touch sensing into the handheld industrial equipment sector

By Dr Andrew Morrison

THE LEVEL OF DEMAND for small format touchscreens based on projected capacitive (p-cap) sensor technology continues to grow at a staggering pace. There is now a clear opportunity for their success within the portable consumer space to be replicated within industrial and enterprise applications.

However, what makes a touch technology good for consumer devices does not necessarily mean it will be equally well suited to professional use. Industrial touch devices will typically be subject to far greater wear and tear. Consequently the chosen touch technology needs to be able to deal with higher degrees of mechanical stress, humidity, and temperature variation, as well as the build up of dirt.

Figures compiled by market analyst firm DisplaySearch show that touch modules based on p-cap technology now represent more than half the total market, both in terms of revenue and unit shipments (see table 1). Clearly, consumer devices account for an overwhelming proportion of this. Almost all of p-cap sensors currently employ a mutual capacitance sensing approach and are based around volume manufacturing processes that are reliant upon the deposition of Indium Tin Oxide (ITO) to form ultra-thin conductive matrices.

ITO has certain electrical and optical characteristics that make it extremely suitable for touch sensing functions, with relatively low levels of resistivity and near transparency when deposited thinly. As a result it is a material that has been widely used in the display industry for many years, and has migrated into touch sensor production - initially within resistive touch screens, then surface capacitive screens (s-cap), and most recently into p-cap systems. With its widespread and long term use in electronic manufacturing, it has been possible for OEMs to adapt existing equipment and install new capacity to respond to the explo-

Dr Andrew Morrison is Technical Director at Zytronic - www.zytronic.co.uk

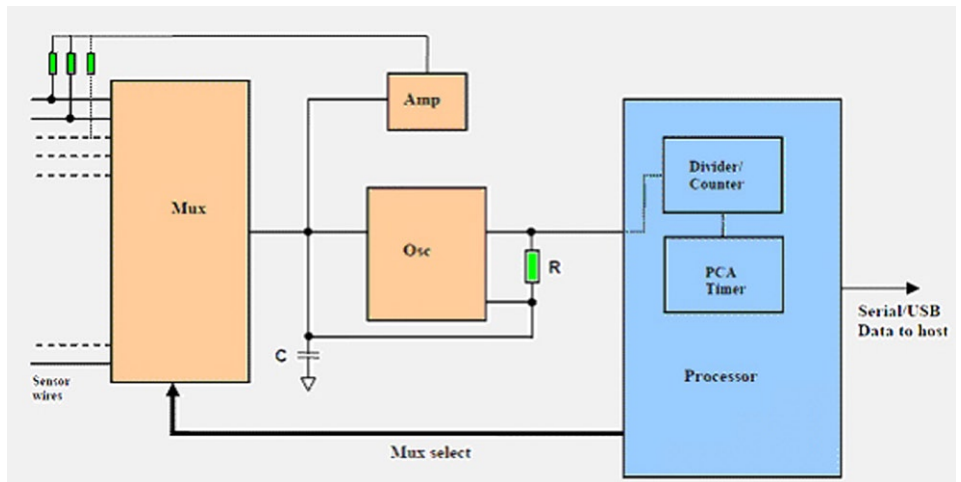

Figure 1: Key components used in a p-cap touch sensor based on frequency modulated self capacitance technique

sive demand for small format touch displays within the consumer space.

Though ITO based mutual capacitive p-cap sensors have seen strong uptake in the consumer designs, the technology does have its drawbacks - with its responsiveness dependent on use of thin glass overlays (<2mm). Whereas this is acceptable, even desirable, for delicate, personal consumer devices, it can be problematic when subject to the rigours they will face in many industrial type settings. Moving from the mainstream, mutual capacitive style of p-cap touch sensing (which measures capacitance between two layers of electrodes) to an alternate self capacitive based method (which measures capacitance of single electrode to ground, with the field generated by the user inducing

slight changes within the field around the sensor matrix) has the potential to greatly enhance sensitivity levels and support operation through substantially thicker overlays.

Self capacitance ITO

When taking a self capacitance approach, the ITO sensor matrix embedded within the touchscreen couples the human body capacitance to the capacitive element of a free running RC oscillator. Touch events can then be detected through introducing a capacitance from glass to finger to ground which is in parallel with the RC oscillator's C element and the oscillator's natural parasitic capacitance to ground. Capacitors in parallel are added so a finger approaching the matrix will raise the total circuit capacitance and

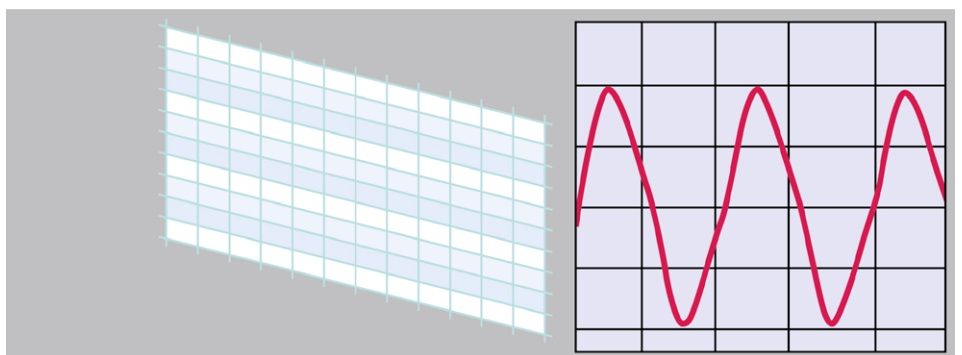

Figure 2: Normal state - Finger far from the sensor matrix.

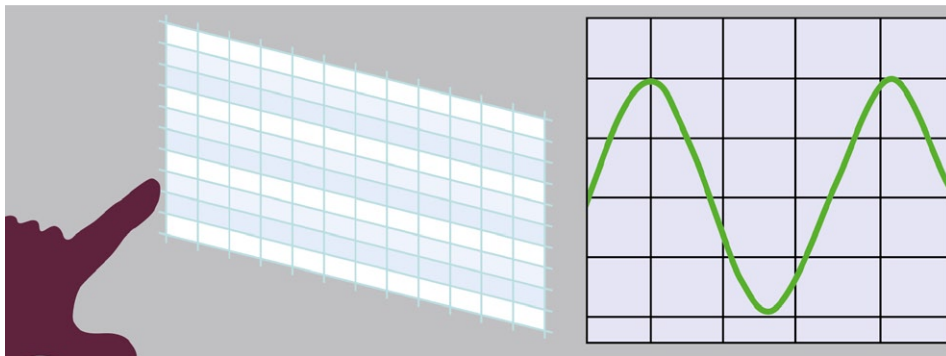

Figure 4: Touch event located through measuring X and Y peak changes in the modulated signal.

thus lower the oscillator's frequency. The capacitance change caused by the approaching finger can be expressed as a percentage using the following equation:

$$\Delta C\% = C_f / C_p + C_c$$

Where: C_f is the capacitance of the finger
 C_p is the circuit's parasitic capacitance
 C_c is the capacitance value of the oscillator

As their finger comes closer to the screen's surface, the user's body capacitance causes a change in the RC oscillation frequency. By measuring the peaks in the frequency change along adjacent X and Y axes of the sensor matrix it is possible to get the precise location where the touch event takes place.

A schematic of the touch sensor's supporting electronics is shown in Figure 1, with the RC oscillator providing the frequency modulated signal to the electrodes. The multiplexer collects the frequency change data from each electrode in the sensor matrix and passes it to the processor IC. Figures 2 and 3 describe the frequency change in one of the electrodes as the user's finger approaches it.

The finger coupling capacitance to the

sensor through a glass overlay which is 3 mm thick typically would be between 1 pF and 3pF. As the thickness of the overlay is increased the coupling capacitance decreases and this will affect the signal to noise ratio. To deal with this more sophisticated supporting electronics will need to be incorporated into the system design. The sensor matrix delivers optimum performance at a supply voltage of 4.7V. At this voltage the current that will be drawn is approximately 2.8 mA.

Self capacitive p-cap sensors using ITO as the conductive medium, exhibit considerably stronger Z-axis sensitivity than their mutual capacitance equivalents. This means they can be placed behind much thicker protective overlays (with strong performance even when operating through 6 mm of overlaying glass) in addition to allowing gloved hand operation. As a result employment of the self capacitive approach can enhance the touchscreen's resistance to extreme impact, drops, scratches, etc, making it highly suited to industrial, medical, white goods and other uncompromising applications, while still offering compelling features, such as gesture recognition, as well as the option to add dual-touch functionality, by accessing the touch controller's firmware via the driver software. ■

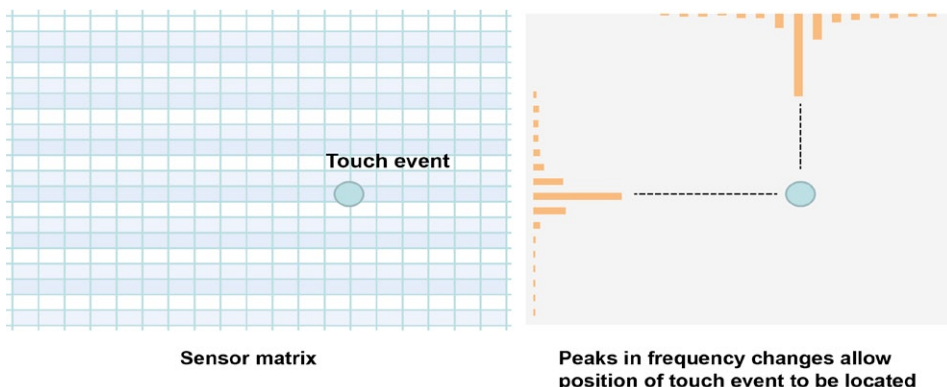



Figure 4: Touch event located through measuring X and Y peak changes in the modulated signal.



GLOBAL LIGHTING TECHNOLOGIES INC.

GLT. The World's Most Efficient LED-Based Edge Lighting Solutions.

General Illumination

LCD Backlighting

Keyboards/Keypads

Touch Panel Illumination



ROTARY



SLIDER



TOUCH PAD







photo: Molex/GLT

+1-440-922-4584
 info@glthome.com
 www.glthome.com

Visit Us at Strategies In Light 2012
 February 7-9, in Booth 731

Research project illuminates OLEDs' industrial future

By Christoph Hammerschmidt

OLEDs (Organic Light Emitting Diodes) have the potential to complement conventional silicon-based LEDs as the lighting technology of the future. Both technologies waste much less electric energy than incandescent lamps and even less than the Compact Fluorescent Lamps (CFL lamps) which have been touted as "energy saving lamps".

Both LEDs and OLEDs generate light out of semiconductors, but in contrast to normal LEDs, OLEDs are flat; they emit their light over their entire surface.

Thus, their light is glare-free and homogeneous; it would ideally complement the punctiform light of conventional LEDs. And since about 20 percent of the world's primary energy consumption is used for lighting applications, more energy-efficient lighting systems certainly would open up great energy saving perspectives.

So far, illumination equipment based on OLEDs is only populating the headlines and the pages of trade magazines. However, they have yet to be seen in general lighting applications in offices and homes. There, CFL lamps and even incandescent bulbs still represent the state of the art in lighting technology (apart from some rare LED lamps). This situation will change gradually over the years to come. Osram and Philips, two major players in lighting technology, have separately recently launched their own pilot production line, but neither of them is eager to communicate details about technology, capacity, production quantity or yield - the experimental character of these manufacturing installations is obvious.

The results of a European research program could bring new energy into this industry. In the OLED100.eu project, 15 partners from six countries have collaborated to further develop OLEDs as a device and the technology to mass-produce them. Among the participants were industrial heavyweights Philips, Osram and Saint-Gobain as well as innovative startups such as Novaled and Microsharp and research institutes - Universiteit Gent, Dresden Technical University and Fraunhofer Institute for Photonic Microsystems, to name just a few.

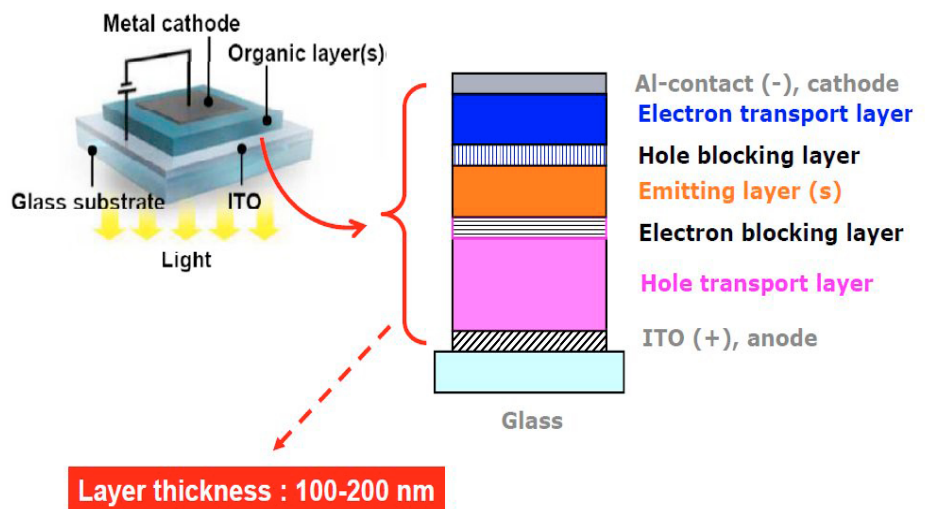

Figure 1: Layered approach - in the basic OLED semiconductor architecture, white light is created by vertically stacked diodes. Source: OLED100.eu

The research targets included developing OLEDs with a high efficiency of 60 lumens per Watt (lm/W) and with a long operating lifetime; the lifetime goal was 100,000 hours. The researchers also addressed one of the potential strengths of such OLEDs: their thin

form factor. The research project also put particular emphasis in developing large-area OLEDs with homogeneous emission. And in order to turn all these features into a real-world product, the researchers also had to put together a low-cost manufactur-



Figure 2: The Fraunhofer IPMS institute developed and tested the industry-scale manufacturing process for the OLED100.eu project.

ing process, enabling the industrial participants to crank up their manufacturing lines.

The goals have been reached - but not all exactly in way it was intended. High efficiency and long life time both have been achieved, albeit not together in the same OLED: the devices are either efficient or lasting. The team succeeded in creating an OLED with a brightness of 60lm/W which means that it was brighter than a CFL of the same wattage. However, the researchers did not elaborate on the life expectancy of this device. In contrast, the lifetime goal of 100,000 operating hours was achieved at an OLED product with an initial luminous intensity of 1000 cd/m². At the end of the projected lifetime, the illuminant has 50 percent of this intensity. This OLED however achieved an efficiency of only 27 lm/W, a hint that there still is a lot of work to be done.

Unlike LEDs, OLED are the most efficient when they are optimized for warm-white light, explained Jan Blochwitz-Nimoth, Chief Scientific Officer of Novaled, a Dresden-based OLED expert company participating in the project. And unlike LEDs, OLEDs generate white light not through separate pixels but through a vertical layering model: a white OLED basically represents three vertically stacked OLEDs. This fact has to be considered when designing drivers or power supplies for OLEDs, Blochwitz-Nimoth explained. Such a triple stack typically requires an operating voltage of 8V; an OLED tile which combines several OLEDs to form a large-area luminary typically requires an operating voltage of 45V. The OLEDs generate an amount of waste heat comparable to LEDs and CFLs. Nevertheless, heat dissipation is easier to handle because the heat is distributed evenly across the relatively large area of the OLED.

The OLED prototype created by the research team is rigid, since it uses glass as a substrate. Basically it is also possible to use a plastic substrate and thus create flexible OLEDs, but glass has far better properties with respect to sealing the product. This is important because OLEDs are very susceptible to humidity; contact with water even in smallest amounts leads to significant degradation. The organic layers have a total thickness of 100 to 200 microns, said project manager Stefan Grabowski. The usage of glass however prevented the designers from creating an extreme slim luminaire, but nevertheless the devices are much thinner than, for instance, a state-of-the art TFT display.

In the development of the production process, the researchers targeted a low cost process which at the same time could be transferred to industrial structures. The homogeneity of the resulting devices remains a challenge, but in most cases the luminance distribution variance across the OLED area cannot be distinguished by the human eyes and can only be measured with highly sensitive instruments. In order to enable such measurements, the standard laboratory of Germany PTB contributed a special measurement setup and process which will be submitted to international standards organization CIE. The manufacturing process itself is rather straightforward - no costly lithography, no photo masks are required. Instead, the process incorporates repeated steps of screen printing, baking and cleaning.

The results will be available to all participants - this means that head-on competitors such as Philips and Osram Semiconductors equally benefit from the work. The differentiation in the competition will then be a matter of industrial design and manufacturing. "The project has delivered a set of technologies which helps us to further develop OLEDs," said Grabowski who is employee of Philips. "Now we need to test the scalability of the manufacturing processes and feed these cognitions into our own production." ■



The CMX7045 Search and Rescue Transmitter (SART) IC - Employing the very latest AIS technology

Features:

- 9600 baud GMSK modulator provides AIS-SART formatted data
- PA Ramp (RAMDAC) automation
- Auxiliary DAC, ADC and System PLL clocks
- Very low power sleep modes in small 48-pin VQFN/LQFP packages



- IEC 61097-14 compliant
- Outstanding performance, total reliability and fastest time to market.



Digital Humidity & Temperature Sensors

Size that inspires!

New version for temperature only!

- I²C Digital Interface
- Fully Calibrated
- Excellent Performance & Reliability

Specifications	SHT21	SHT25	STS21
Range RH	0% to 100%	-	-
Range T	-40 °C to +120 °C		
Accuracy RH	2% RH	1.8% RH	-
Accuracy T	0.3°C	0.2°C	0.2°C
Consumption	3 µW	3 µW	3 µW

SENSIRION

THE SENSOR COMPANY

SENSIRION AG 8712 Staefa ZH
Switzerland © +41 44 306 40 00
www.sensirion.com

humidity | gas flow | differential pressure | liquid flow

Super bright TFT LCDs

deliver 1500cd/m² for industrial applications

Optrex America has introduced three super bright TFT LCDs designed for use in outdoor environments, including direct sunlight and other high-ambient-light environments, such as a brightly lit factory floor, where the display has to be readable at all times in any environment over a wide temperature range.



The 19" diagonal T-55699D190J-LW-A-AAN has a 1280x1024 resolution, a brightness of 1500cd/m², draws 33.2W power consumption with a contrast ratio of 800:1, and wide viewing angles ranging from -80° to +80°, horizontal and vertical. It also features a wide operating temperature range of -20° to 70°C, a white LED backlight with

100K hour lifetime, and includes a standard LVDS interface. The 12.1" diagonal Super High Bright TFT LCD (P/N T-55592D121J-LW-A-ABN) features 1280x800 pixels, draws 13.1W and operates in the -30 to 80°C temperature range. It has a 700:1 contrast ratio, with wide viewing angles of -80° to +80°, horizontal and -60° to +80° vertical.

LVDS interface is standard. The 9.0" diagonal Super High Bright TFT LCD (P/N T-55562D090J-LW-A-ACN) has a resolution of 800x480 pixels, draws 6.4W and offers a contrast ratio of 800:1, with the same viewing angles as its 12.1" counterpart.

Optrex America

www.optrex.com

7-inch and 10.6-inch colour TFT-LCDs

LED-backlighting, high temperature range

Mitsubishi Electric launched 7.0-inch WVGA (800x480 pixels) and 10.6-inch WXGA (1280x768 pixels) colour TFT-LCD modules featuring white light-emitting diodes (LED) and extended backlighting. These industrial-use modules, suitable for outdoor applications such as digital signage and marine electronics, offer



super-high brightness and high contrast ratios, super-wide viewing angles and wide-ranging operational temperatures.

Both models are expected to help meet the increasing demand for TFT-LCD modules offering high brightness up to 1,000cd/m² and a high contrast ratio of 1,000:1 for easy viewing even in bright outdoor environments. The very wide 170-degree horizontal and vertical viewing angles enable

highly functional visibility and extra flexibility for off-centre installations. The display units operate from -30 to 80°C, allowing the modules to be exposed to severe climatic environments in

outdoor applications. At 25°C, the white LED backlight unit is rated for a typical life of 100,000 hours and a high-voltage inverter is not required. The TFT-LCD module is fully compliant with the European restriction on the use of certain hazardous substances in electrical and electronic equipment.

Mitsubishi Electric

www.MitsubishiElectric.com

Multi-functional programmable display

built in a fire-resistant high impact housing

The GeBE Indico from GeBE Elektronik und Feinwerktechnik is a 3.5" or 4.3" touch TFT display built in a fire resistant, high impact resistant housing per DIN96x96 or DIN144x96. Its versatile control features are complemented by the option to combine multiple displays. This

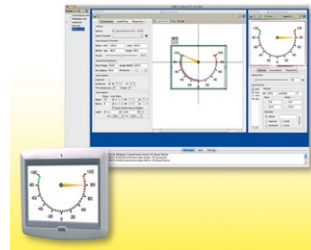

flexible I/O instrument is aimed at industrial and transport applications in rugged environments. The unit can also be used in outdoor applications and features a vibration-stable construction paired with front side IP67 protection and temperature stability between -20 and 70°C. The panel's intelligent controls offer extended life time to the

crisp 230x240 or 480x272 pixel displays, it can be configured via a PC to decide on style, touch-key functionality or interfaces without any programming knowledge. The display is controlled through USB, RS232, and RS485 interfaces or via a CAN bus. Isolated GPIOs as well as analog I/Os are also standard features of this

instrument series. A real-time clock and an SD card transform the instrument into a data logger. Customer specific options with respect to chassis color and instrument configuration are possible starting with medium order quantities.

GeBE Elektronik

www.oem-printer.com

Operator terminal computer

for production floor environments

Captec has introduced the OTC-51, a ruggedised operator terminal computer specifically engineered for production floor environments. It has been designed to be easy to clean, easy to operate, and easy to mount, for both machinery and process automation applications, such as manufacturing



execution systems. Sealed all the way around, the computer is IP66 rated making it suitable for use in production floor environments where fluid and dust are common. Its aesthetically pleasing appearance allows for OEM branding and comprises a stainless steel bezel, which makes the terminal suitable for use in the food, beverage and pharmaceutical industries where high pressure wash-down is common.

Standard computer cables and connectors are attached through a sealed cable entry bay. The OTC-51 is operator friendly with VESA mounting capability and

5-wire resistive touch screen, allowing the terminal to be conveniently located and operated whilst wearing gloves. Also contributing to its ergonomics is the high

resolution widescreen display, making it compatible with standard PC application software, ensuring operator familiarity. Running on an Intel Dual Core Atom Processor, the OTC-51 is powerful and efficient. The terminal comes with a protected USB port on the front bezel for flexible data transfer.

Captec

www.captec.co.uk

SPECIAL FOCUS: DISPLAY TECHNOLOGIES

Single-chip solution

suits direct lamination onto large touchscreens

Cypress Semiconductor's CY8CTMA884 family of single-chip TrueTouch controllers for large touchscreens enables large-screen sensor-on-lens technology with direct lamination to the LCD. The technology allows manufacturers to deposit the conductive Indium Tin Oxide (ITO) sensor lines directly onto the cover glass. It only requires one panel, so tablets can be made much thinner, with less material costs and fewer manufacturing steps. The CY8CTMA884 enables the cover glass to be directly laminated to the LCD with a thin adhesive layer and no added shield layer. Many other solutions fail in this configuration because the increased electrical noise from proximity to the screen interferes with the ability to correctly interpret touches. Cypress's proprietary noise immunity technology and

high signal-to-noise ratio enable flawless performance in this configuration.

The high-performance, single-chip CY8CTMA884 TrueTouch solution for large multitouch touchscreens up to 11.6 inches offers 60 sensing I/O channels with support for up to 884 nodes on the screen, more than any other single-chip solution. Additional sensing channels are essential for greater accuracy, linearity, support for smaller sized fingers and the ability to resolve multiple fingers close together. The CY8CTMA884 offers all the benefits users have come to expect from TrueTouch devices, including 10-finger touch support, low power consumption, grip and palm rejection, high accuracy, and fast scan times.

Cypress Semiconductor

www.touch.cypress.com

Transparent LCD monitor

22" colour unit, 1680x1050 pixel resolution

Crystal Display Electronics has unveiled what the company claims to be Europe's first transparent 22" colour display to be available ex stock. The transparent 22" colour display features 1680x1050 pixels of resolution and a contrast ratio of 500:1. The transparent active picture area measures 474x296mm and has a viewing angle of 160°, horizontal and vertical. The colour screen can also be switched to black & white mode. In order to ensure that the LED backlight is evenly illuminated, the 84 LEDs are covered with a gel filter. The LED backlight bar is fitted in the top frame, which also includes a DVI and VGA interface. Current consumption can be significantly reduced by using the screen without its backlight bar. In this case, the ambient light in the

room (e.g. sunlight) can be used as an alternative light source. The unit can be used as internal and external shop displays, in museums and exhibitions as



glass display cabinets, in the educational sector and in the public transport sector (for example on windscreens).

Crystal Display Electronics

www.crystal-cde.com

Ultra-compact power MiniLEDs

AEC-Q101-qualified, deliver 1400mcd

Vishay Intertechnology, Inc., has released a new series of power MiniLEDs in ultra-compact 2.3 mm by 1.3 mm by 1.4 mm SMD packages. Utilizing the most advanced AlInGaP technology to increase light output by a factor of three, devices in the VLMx233.. series are AEC-Q101 qualified for automotive applications and are offered in super red, red, amber, soft orange, and yellow. The high-intensity LEDs released today provide low thermal resistance junction/ambient of 480 K/W and power dissipation up to 130 mW, which in turn enables high drive currents up to 50mA. The devices output up to 1400 mcd and feature a ±60° angle of half-intensity. The LEDs are categorized per pack-

ing unit, for luminous intensity and color. Compliant to RoHS Directive 2002/95/EC and in



accordance to WEEE 2002/96/EC, VLMx233.. series devices are available in 8 mm tape and are compatible with IR-reflow soldering processes and preconditioning according to JEDEC Level 2a.

Vishay Intertechnology

www.vishay.com

TOUCH
SCREEN

Integrated Solutions

- Continuous closed front foil, IP 65
- No dirt edge, plane surface
- Front anti-reflective, scratch-, and chemical-resistant
- Optional combined with keypads
- Panel: Complete solution for front installation

www.schurter.com/is_news

SCHURTER

ELECTRONIC COMPONENTS

Increasing system performance through the use of optical encoders

By Swee Hing Young

OPTICAL ENCODERS HAVE been used to measure position, speed, acceleration and motion direction for decades, but now they are finding new applications where high performance and miniaturization are mandatory design goals.

New encoder technology has been developed with a focus on low power, very compact size, and low cost to enable autofocus and zooming mechanisms in digital still cameras and phone cameras. Consumer goods such as sewing machines, gaming equipment and surveillance cameras also benefit from compact encoders. Medical equipment and products such as insulin pumps, portable medical equipment, electronic wheel chairs and optometric equipment require low power, high resolution and full three-channel encoding capability.

Modern encoders must fit into the ever-reducing physical size of modern day applications, but high-performance applications cannot settle for a solution that offers less than full capability or that requires external circuits to generate an index channel. The code wheel design is also a factor in overall size. For example, the Avago AEDR-850x three-channel encoder does not require a separate circular track for an index channel. This allows the code wheel to have a very small diameter. In a new design with a focus on size, the encoder and code wheel requirements must be considered together.

A closed-loop motion feedback architecture is shown in figure 1. In this example, a compact encoder and a code wheel are mounted within the miniature motor housing. Until recently only two-channel encoders were possible because adding the third or index channel increased the diameter of the code wheel beyond the available space.

Compact encoders with full capability

The Avago AEDR-850x reflective encoder integrates an LED light source, photo detector, interpolator circuit for higher counts per revolution (CPR), and three channel (A, B

and Index) encoding capability into a single package with a 3.95x3.40mm footprint. It is just 0.9562mm high, encased in a single epoxy dome construction. Using this optical incremental encoder as an example, one can develop a motor control system with an encoder and code wheel, as shown in figure 2, with a code wheel diameter of just 4.6 mm and code wheel optical radius (Rop) of 1.7mm. Encoder operation requires only a 5V supply and a single 180 Ω LED biasing resistor for a three-channel encoding. The resistor, R, sets the internal LED current to approximately 15 mA.

Small diameter code wheels

Before the Avago AEDR-850x, an incremental encoder with a third, or index, channel was not possible for miniature applications because the code wheel became too large with the addition of a separate index track. Patented single-track code wheel technology from Avago embeds the index information into the existing channel A and B track.

This allows a compact encoder with three-channel encoding capability to be made without requiring a physically larger code wheel. While a conventional three-channel optical encoder typically features a separate track for the A and B channels, and a separate optical track for the index, the AEDR-850x features a single track for the 3 channels, saving on space and power.

By comparison, competing laser-based three-channel encoders are more expensive and require much higher power consumption than LED encoders. Those solutions are also much larger, as much as seven times larger than the AEDR-850x reflective encoder. With the AEDR-850x, the index channel width is three times the angle of an opaque area width. The index is “embedded” into the existing AB track.

Note that for the embedded index track design, two opaque bars are used for the index, reducing the overall physical bar count. However, this does not reduce the counts per revolution, CPR, as the count during the index transition is generated by an intelligent signal processing circuit within the AEDR-850x.

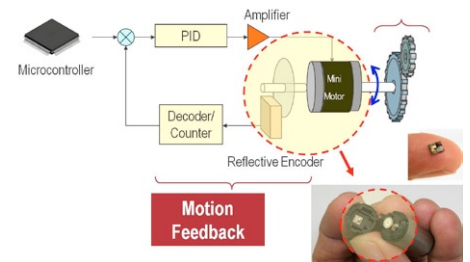

Fig. 1: Compact encoders allow three-channel closed loop control.

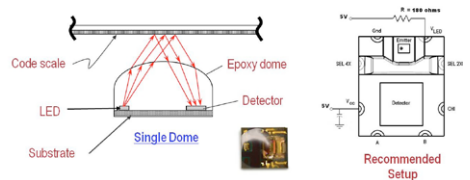

Fig. 2: Reflective optical encoders can be made compact and with three channels.

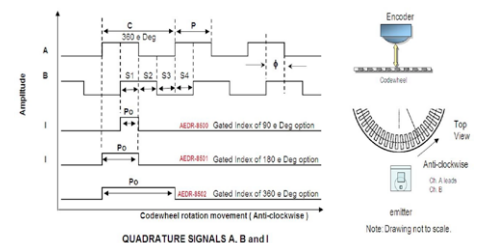

Fig. 3: AEDR-850x three-channel optical encoders with gated index channel have “Home Position” indication.

Third channel gives absolute “home position” indication

A typical optical encoder has two digital output channels, channel A and channel B; the channel outputs are offset by 90 electrical degrees (°e), and this configuration defines what is called quadrature output signals. When the code wheel rotates counterclockwise, as shown in figure 3, channel A leads channel B. When the monitored motor shaft reverses direction, channel B leads channel A.

Hardware or software easily determines rotational direction from the quadrature signals as well as relative position, speed and acceleration. All measurements are relative in an incremental encoder system, since the

Swee Hing Young is a Technical Marketing Engineer for Motion Control Products at Avago Technologies - www.avagotech.com

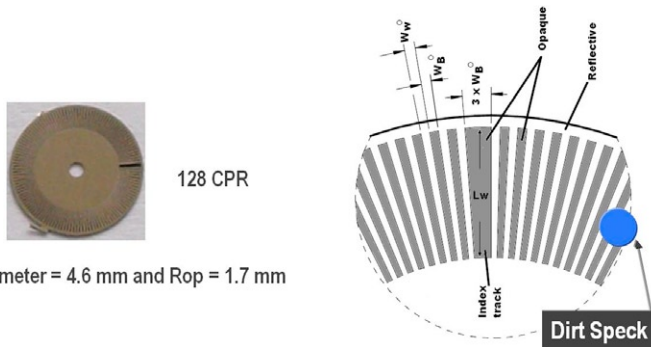

Fig. 4: Miniature code wheels should be free of dust and contaminates for consistent operation.

two channels do not output absolute position. For absolute position information, a more complex and more expensive absolute encoder would be needed. However, by adding an index channel to an otherwise two-channel encoder, a “home” position or zero reference is available. This method is universally used in lower cost systems. Depending on the application requirement, the encoder’s index channel can have a gated 90°e, gated 180°e or ungated 360°e pulse width as shown in figure 3.

Code wheel calculation equations are easy

Once an encoder is selected the code wheel design begins. Equations 1 and 2 are all that is needed to design a code wheel that matches your encoder’s line per inch (LPI) specification and counts per revolution (CPR) design goal.

$$CPR = LPI \times 2\pi \times Rop \text{ (inch)} = LPmm \times 2\pi \times Rop \text{ (mm)}$$

Equation 1: CPR, LPI and Rop relationship

$$RPM = \frac{60 \times f}{CPR}$$

Equation 2: Maximum shaft RPM for CPR and encoder frequency
Code wheel optical radius, Rop, calculation for a given encoder LPI/ LPmm and desired counts per revolution CPR, uses equation 1.
Let’s say, with a design requirement of 828 CPR and with the AEDR-850x’s fixed 304 LPI specification, the optical radius, Rop, in mm is:

$$Rop \text{ mm} = \frac{828}{2\pi (304/25.4)} = 11.01 \text{ mm}$$

At 828 CPR and a 1x interpolation setting, the maximum revolutions per minute (Rpm) the design supports are calculated by equation 2:

$$Rpm = \frac{60 \times 55000}{828} = 3985$$

The AEDR-850x maximum count frequency, f, is 55 kHz with a 1x interpolation setting, but with the same Rop size, CPR can be increased with the AEDR-850x by selecting a different interpolation factor through two TTL compatible logic signals, SEL 4X and SEL 2X, as shown in .

Keep miniature code wheels clean

As with all encoders, the code wheel should be kept free of dirt for consistent performance, but this is especially important for a three-channel reflective encoder. As the index track is generated by a 3 x WB opaque (non-reflective) region, any dirt that blocks the tracks can result in the detector seeing a 3 x WB region, which will generate

Interpolation Pins		Interpolation Factor	Counts per Revolution (CPR) for Rop = 11 mm	Count Frequency
SEL 4X	SEL 2X			
LOW	LOW	1X	828	55 kHz
LOW	HIGH	2X	1656	110 kHz
HIGH	LOW	4X	3312	220 kHz
HIGH	HIGH	Factory use only		

Table 1: AEDR-850x interpolation factors increase the counts per revolution, CPR.

an erroneous index signal. Figure 4 illustrates the potential error dirt can cause with a miniature three-channel code wheel. Control applications can now benefit by having A, B and index channels using a single code wheel track.

In addition, 1x, 2x and 4x interpolation capability gives increased counts per revolution without the need for a new and larger code wheel design. Design reuse across different end products is possible with little or no new design work. ■

Not only highly sensitive

for the measurement of low differential pressures but also ...

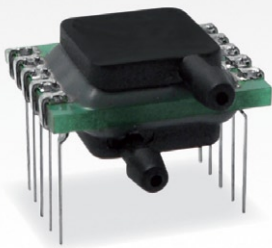

- **robust:** immunity against dust and humidity
- **innovative:** flow channel integrated within the sensor chip
- **high resolution:** analog CMOS signal conditioning
- **space saving:** miniature PCB-mountable housings

SENSORTECHNICS
www.sensortechinics.com

Hyperspectral imaging: seeing the invisible

By Dr. John R Gilchrist and Suvitha Karthick

SHRIMPS SEE WHAT WE, humans don't see. Mantis shrimps have a compound eye which allows them to see in the ultraviolet down into the infrared whereas human eyes can only detect the visible portion of the electromagnetic spectrum. This allows mantis shrimps to detect preys which would appear transparent to our eyes. This is just an example of what lies beyond what human eyes can see.

Similar to the way how these shrimps scan the world across different wavelength bands, the hyperspectral imaging (HSI) technique collects information of a target scene across the electromagnetic spectrum, from ultraviolet to long-infrared. This enormous information facilitates the identification of objects. For example, HSI in the Shortwave Infrared (SWIR) spectral region provides detailed information about the chemical composition of tablets, which is not possible using normal imaging. The HSI technology has the potential to transform early detection and treatment of many life-threatening medical conditions. It can be used in dentistry to detect tooth decay without drilling or x-rays, help farmers to monitor crop's health, in the detection of counterfeit goods and in the quality assessment of food products. Let's look at the hyperspectral image in detail.

A hyperspectral image cube consists of a set of images layered on top of one another. Each image represents one particular wavelength band. This set of images form what is termed "the hypercube" illustrated in figure 1. Thus in a hyperspectral image, each pixel consists of a spectrum over an appropriate spectral region. Every object has a unique characteristic across these different wavelength bands. This unique characteristic is referred to its 'spectral signature'. For example, by comparing the spectral signature of the unknown target objects to that of known substances, the chemical composition of the target object can be identified. The property of HSI, which looks beyond the visible spec-

trum, enables not only the identification of objects but also their classification and quantification to a high degree of accuracy.

The hyperspectral systems designed and built by Gilden Photonics employ a push-broom imaging technique. In this technique, the spectral signature of one pixel to many thousand pixels in a spatial line (swath) across the target area is recorded at a time. The second spatial dimension is built over time by sequentially recording one swath after another – see figure 2.

How does push-broom technique work?

The push-broom technique allows the simultaneous acquisition of all spectral bands. The three main components of a push-broom hyperspectral camera are a CCD camera (two dimensional detector array), imaging Spectrograph and objective lens. The fore optics, in a hyperspectral camera, image the light reflected from one line segment of the target sample onto the entrance slit in the spectrograph. This light is dispersed into different wavelengths by the dispersing element (prism/grating) in the spectrograph. This dispersed light is captured by the CCD sensor as a two dimensional image $[X, \lambda]$ with X representing the spatial position and λ the spectral dimension. In order to capture the entire image, snapshots of every line across the target area have to be captured. A schematic representation of push-broom imaging is shown in figure 3.

To capture the images of different lines on the target area, users can either move the target object, the spectral camera, or a scan mirror in front of the camera and in a perpendicular direction to the measured line. By synchronising the movement between camera and target object and the acquisition of the camera, one can capture different lines of the object and thus generate the hypercube $[X, Y, \lambda]$ where Y represents the second spatial dimension. This technique works in a similar fashion to the pushing of a broom across the floor, hence the name. Gilden Photonics employs appropriate scanning systems in their hyperspectral imagers to facilitate the

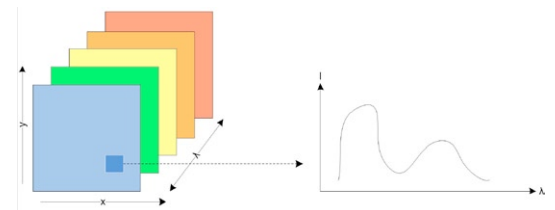

Fig. 1: Hypercube conceptual representation.

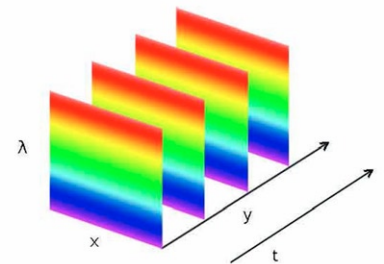

Fig. 2: Capturing spatial dimension over time.

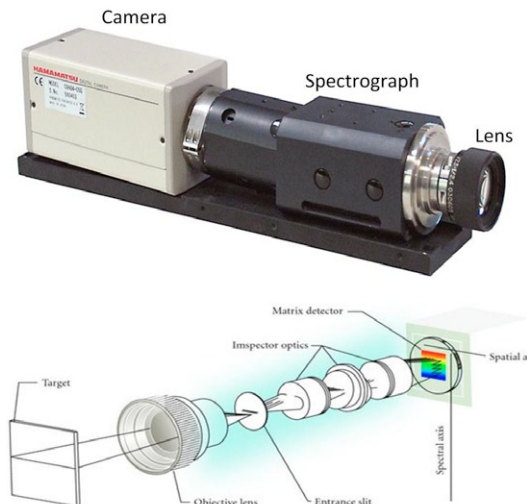

Fig. 3: Hyperspectral camera and schematic representation of push-broom imaging.

movement between the camera and the target scene.

The push-broom HSI systems are highly rugged and more stable. These systems allow rapid HSI acquisition. The complete spectral information of a line is acquired simultaneously along with the spatial information. This facilitates high throughput and hence faster hypercube generation. The push-broom technique also allows reduced illumination load. Only one line across the target area needs to be illuminated at a time.

This reduces the heat load on the sample drastically compared to other imaging techniques. The push-broom HSI systems are ideal for online measurements with moving objects. These systems can be directly transferred from R&D labs to production line in industry with no changes to the system. For example, this can be applied for fruit sorting where the fruits are constantly moving over a conveyor belt.

Dr John R Gilchrist is Managing Director at Gilden Photonics – www.gildenphotonics.com - He can be reached at info@gildenphotonics.com.

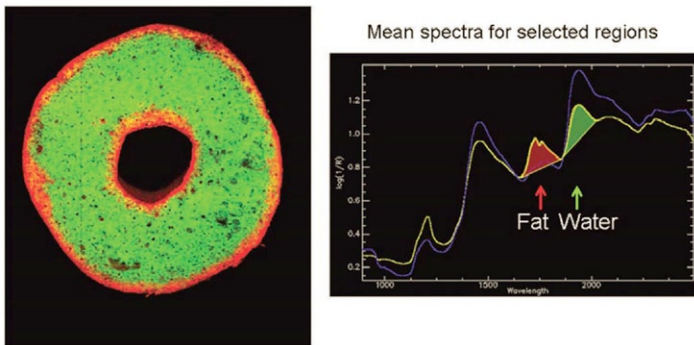

Fig. 4: Frying fat and water content in a doughnut (Image from CCFRA, Campden, UK)

Some applications

Hyperspectral imaging is a non-destructive, non-contact technology which makes it well suited for a wide range of applications including for remote sensing, identification of tumours in biomedical applications, food process monitoring and so on. Researchers at Campden & Chorleywood Food Research Association (CCFRA) and Gilden Photonics developed a HSI system to determine the distribution of fat and moisture content in fried foods, distribution of fat in meat, freshness of fish and evaluation of baked goods. Conventional techniques such as NIR spectroscopy were able to provide only the average fat content in food. HSI facilitated the analysis of non-uniform distribution of fat in doughnut. In figure 4, a doughnut has been measured in the NIR region, showing the fat and moisture contents as separate characteristic absorbance bands.

Hyperspectral imaging in Near-Infrared (NIR) and Shortwave Infrared (SWIR) region provides information about the spatial distribution of chemical components in pharmaceutical samples. The pharmaceutical applications of HSI range from R&D, to production line in industries for quality inspection.

Figure 5 shows how different ingredients and homogeneity in their distribution in tablets is detected in the NIR image (left) based on different spectra of the ingredients (right). HSI has been increasingly applied in forensic industry such as Inks examination on questioned documents like altered date on contract signature, examination of samples like fibres and paint cut offs for trace evidence, detection of counterfeit samples and so on. The series of pictures in figure 6 highlights some alterations in a forged cheque. In 2010, Gilden Photonics launched a Hyperspectral fluorescence lifetime imaging system which combines the advantages of spectral imaging with time resolved measurements. This unique multi-dimensional measurement and analysis technique provides enormous amount of information about the sample. This technology would take the object classification and quantification to an entirely different level. ■

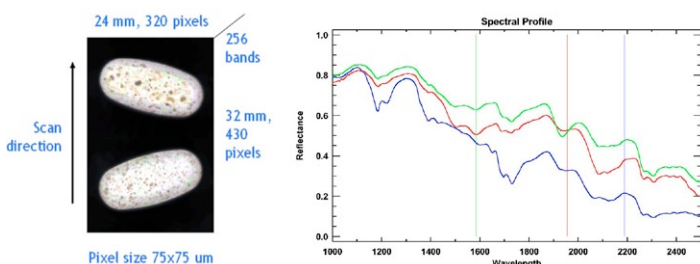

Fig. 5: Ingredient homogeneity and distribution in tablets is detected in the NIR image (left) based on different spectra of the ingredients (right).

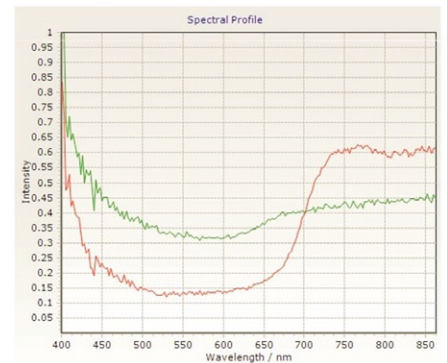
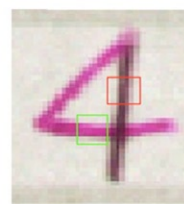
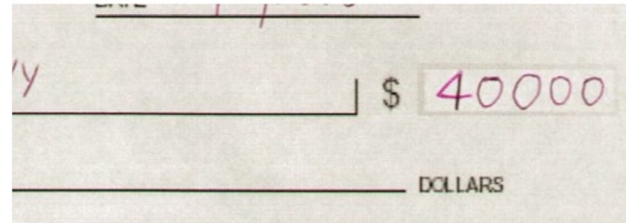

Fig. 6: False colour hyperspectral image of the cheque created with three different wavelength bands. This shows that the number '1' has been altered to number '4'. The reflectance spectra of the horizontal line (green plot) and vertical line (red plot) in the number '4' show that different inks were used.



Standard and custom passive components

If your application depends on it



MICROSWITCHES AND POSITIONSWITCHES

- IP67 sealed
- Long life
- High precision
- Temperature resistant

LED ASSEMBLIES

- Custom board mount and panel mount
- Rugged IP66 indicator lights
- RoHS compliant

METAL FOIL RESISTORS

- Close tolerances
- MIL and NASA approved

Microprecision Electronics SA is a manufacturer of precise passive components like microswitches, position switches, LED components and metal foil resistors.

Visit us at : www.microprecision.ch

MICROPRECISION ELECTRONICS SA

P.O. Box 160 ■ Route de l'Industrie 27
CH - 1896 Vouvy ■ Switzerland
P +41 (0)24 481 43 43
F +41 (0)24 481 43 60

Integrated sensor nodes with GSM modems: simplifying the task of wireless data acquisition

By Ajay Bharadwaj and Balaji Mamidala

A **SENSOR NETWORK** typically consists of a number of sensor nodes which each acquire signals from a sensor or multiple sensors and a system to transmit and process the data acquired from sensors. The sensor nodes can communicate the data within one another or to a centralized location over a wired or wireless network.

The sensor network can thus be classified as a data acquisition network and data distribution network. The data acquisition system typically consists of sensors and circuitry to handle the real-world information available and the data distribution network involves the communication protocols, network topology, and methodology to transmit and handle the data. The basic network topologies used are star, ring, bus, and mesh, as shown in figure 1.

The choice of the sensor network topology depends upon the application and the kind of processing and data handling required. The need for improving connectivity from PCs to the real world is gaining momentum. There are a many sensors and actuators in use, and interconnecting them by integrating the data available is becoming a necessity. The numbers of nodes in a sensor network continues to increase and wired connectivity is often not an option since sensors must be placed in remote locations. The cost per node is also decreasing, enabling wider reach of sensor nodes. There are also many improvements in low power radio technologies which can be used to design more efficient systems.

Wireless networks also offer better scalability compared to wired networks and deploying a new node in a wireless network is easier. Sensor networks need to balance performance versus the lifetime of the sensor node. Wireless nodes can be configured dynamically to balance this tradeoff, as well as operate autonomously to permit local control of operation and power management. A number of wireless protocols can be considered for sensor networks namely

Zigbee, Bluetooth, GSM, Wi-Fi, etc.

The choice of wireless protocol depends upon the application needs for the sensor network.

Low power capability

Wireless sensor nodes require very little maintenance and must run for days and sometimes months using the same battery. Thus, low power design is critical for the design of real-world wireless sensor networks, and it is a primary requirement that sensor nodes process and transmit sensor data while consuming very little power.

As sensors in a sensor node typically measure slow varying analog quantities, nodes need only be active for a short duration to transmit data before they go back to sleep. This means that sensor nodes have to have excellent standby current capabilities. Also, most of the data transmission occurs between the sensor nodes to the base station.

Network architecture and communication protocols must exploit this asymmetry of sensor communication from sensor node to base station. Design of a low power sensor is critical. Micro Electro Mechanical Systems (MEMS) based sensors with low power capabilities are also critical. Sensor nodes may operate in an environment of densely distributed nodes from different sources. Sensor nodes may also need to transmit using very low power in noisy environments.

Aggregation of data from sensor nodes

The data from a sensor network must be aggregated and processed in a centralized location. Data handling in a sensor network can be split into data dissemination and data gathering. Data dissemination is the process by which information is routed in the sensor network. This information could be data acquired from the sensor or requests for data from other sensors. A number of algorithms are available for disseminating data across a sensor network. Data gathering algorithms

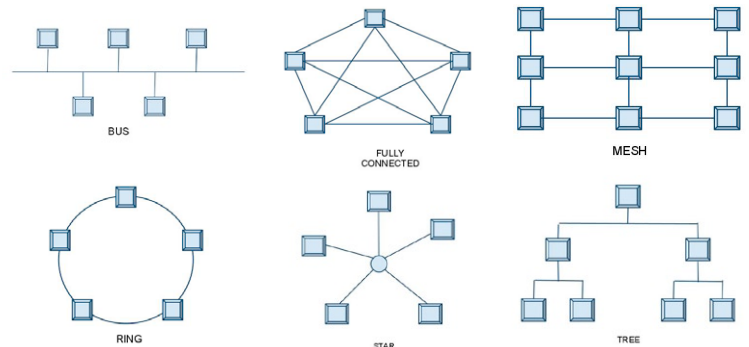

Fig. 1: Various network topologies.

maximize the number of communications that happen with a sensor node before the node dies. The trade off in this case is between delay and power consumption. In case of a direct transmission, every node sends collected data directly to a centralized network as in the case of nodes with GSM capabilities. Nodes of a wireless sensor network would have an operating system ported onto it. This enables an easy expansion through the addition of more wireless sensors. The operating systems for sensor networks resemble embedded operating systems since they are developed keeping an application in mind and are not generic. Also, since the system is built with low power and low cost capabilities, most general purpose operating systems must be eliminated. Given that most sensor networks do not require real-time capabilities, a smaller operating system such as TinyOS that has been specifically designed for sensor nodes may be used.

Figure 2 shows a typical implementation of a sensor network using a GSM (Global system for mobile communication) modem. Here all of the sensors communicate their data to a centralized server. The server has control over individual sensor nodes; however, individual sensor nodes cannot communicate between themselves. The server has to be involved for any communication between any two sensor nodes.

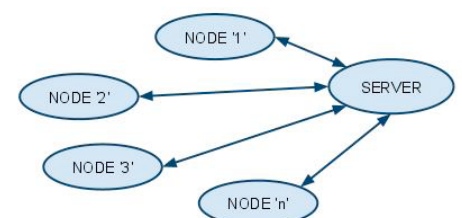

Fig. 2: Typical implementation of a sensor network.

Ajay Bharadwaj is Senior Applications Engineer at Cypress Semiconductor - www.cypress.com - Balaji Mamidala is Applications Engineer.

GSM modem

GSM (Global System for Mobile communication) is one of the standards for mobile telephony in the world. Although initially used only for voice communication, it has been adapted to include data capabilities by means of GPRS (General Packet Radio Service) and EDGE (Enhanced Data Rates for GSM Evolution). A GSM modem is a type of modem which accepts a SIM (Subscriber Identification Module) and operates like a mobile phone. GSM modems can be used in low power mode or can also be turned off when they are not in use. The cost of transmitting data by GSM networks is has been falling rapidly. What's more, a GSM modem can easily be interfaced to microcontrollers using standard communication protocols. Mobile phones are increasingly handling data along with voice. Most GSM modems have a TCP/IP stack implemented on them and can be used to transmit data over secure channels. This also reduces the complexity of developing applications and enables the use of simple microcontrollers to interface to the GSM modem.

A GSM modem can connect to any IP (Internet Protocol) address and transmit data. Multiple modems can send data to a single IP address, and all the data can be collected and processed from a single location anywhere in the world. Users can dynamically configure each and every modem remotely based on data sent across from the network. In certain networks, a single node would have GSM capability. Other nodes would send their data to this particular node to be transmitted to the centralized server. This could reduce the cost of the overall system but would not be possible if nodes are not clustered together. GSM modems also have the ability to provide instant alerts using SMS (short messaging service) or by transmitting data to a different, high-priority IP address based on certain conditions. These features can be used for fault tolerance and redundancy checks.

Let us consider an example of a GSM modem (SIM300) where communication happens over a serial port with the microcontroller. The modem has a standard set of commands called AT commands. These commands control the operation of the modem from the microcontroller. The microcontroller sends these commands over a UART (Universal Asynchronous Receive Transmit) interface at a specified baud rate. The data sent through the serial port can be transmitted to a centralized server by configuring the modem using a specific set of commands. Thus, interfacing with the GSM modem simplifies data acquisition and processing in sensor networks.

Complete system implementation

A sensor node consists of an analog signal chain and also requires a host of digital peripheral interfaces. Also each sensor node may be interfaced to different kinds of sensors, requiring flexibility in its interfaces and I/Os. Programmability of individual nodes plays a critical role in a successful implementation of a sensor network.

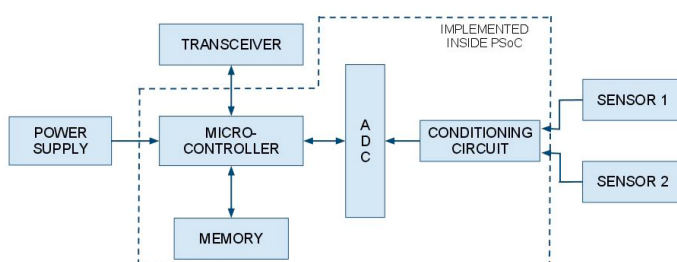

Fig. 3: Simplified implementation of a sensor node using PSoC.

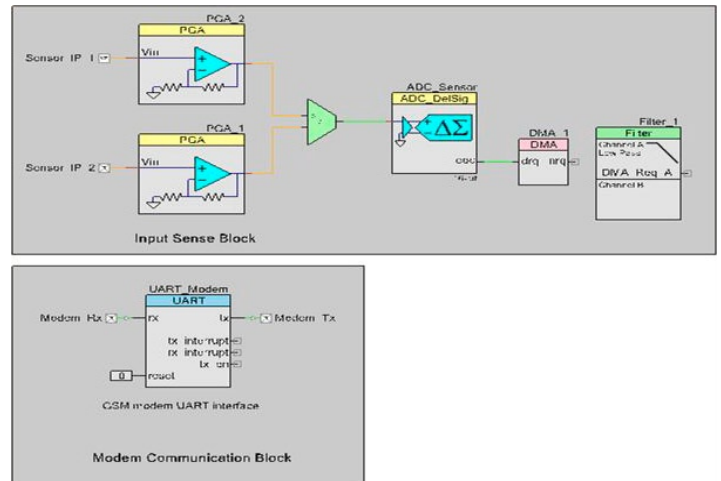

Fig. 4: An implementation of a sensor node using PSoC.

Mixed-signal programmable microcontrollers like PSoC from Cypress provide analog and digital subsystems which can be configured to provide the functionality required by individual nodes. This eliminates the need for specialized hardware for each different kind of sensor. Such System-on-Chip-based (SoC) MCU also have the capability to handle all tasks required for the sensor node in a single chip, including ADC, DAC, PGA's, comparators, op-amps, digital filtering capabilities, DMA, and LCD controllers, among others. Design of the system using SoCs allows frequent and fast changes in design to assist customization of sensors nodes. PSoC with its low power capabilities at sleep mode is very suitable for these applications. ■

contact@absopulse.ch

www.absopulse.ch

High-Performance, high reliable Power Supplies
15 W to 12 kW+ adapted to your challenging projects

- AC/DC Power Supplies
- Rectifiers and Battery Chargers
- DC/DC Converters
- Sine-Wave Inverters
- Phase and Frequency Converters
- AC- Input, DC-output UPS systems
- Open Frame
- Wall mount
- 19" Cassettes
- DC-input dimmable back-light inverters for LCD displays
- Complete Power Systems in 19" and 23" Racks

ABSOPULSE Marketing Europe GmbH
PoBox 1501
8620 Wetzikon CH
Tel. +41 78 896 50 49
Fax +41 44 944 38 44

Write us: contact@absopulse.ch

See us: www.absopulse.ch

Sensing electrical potentials for medical applications and touchless control

By Phil Watson

EVERY ENGINEER IS FAMILIAR with the voltages and currents in an electric circuit. These quantities can be measured easily enough with the two probes of a digital voltmeter. But few are familiar with the electric potentials associated with activity within the human body. Fewer still are aware of the electric fields we perturb whenever we move around a room.

These signals, and the information embedded within them, are not apparent to most of us because a digital voltmeter or even a high-speed digitizing oscilloscope, cannot measure them. Laboratory electrometers with impressively high input impedances and mechanical field-mills go some way to reconciling the measurement of electric potential with the reality. But these devices have various issues that have prevented the widespread application of electric potential sensing, in particular the need for frequent recalibration.

In order to investigate quantum circuit behaviour at very low temperatures, the University of Sussex needed an ultra-stable, non-contacting electric field sensor, and the EPIC (Electric Potential Integrated Circuit) sensor was the result. Its sensing element is a metal electrode which is coupled to circuitry with an ultra-high input impedance, causing it to act as a high sensitivity, non-contacting voltmeter. It is designed to measure very small changes in electric fields and can resolve down to mV levels with an ultra-high input resistance, typically 5×10^5 , dry-contact capacitive coupling, low input capacitance of 10-11 F and an upper 3dB point typically at 20 kHz.

EPIC represents an entirely new category of sensor with the ability to conveniently measure multiple sources of electric potential with a single solid-state IC. Because electric fields arise from many diverse sources, the applications are numerous. An EPIC can be thought of as a near-perfect voltmeter because its high input impedance means that no real current is drawn from the source.

The sensor requires no direct electrical

connection to a source as the potentials are sensed by capacitive coupling to an insulated electrode. The actual interaction with the target field is kept to an absolute minimum so that all currents are small displacement currents only, when means that the sensors require very little battery power making them suitable for portable devices such as continually worn sensors. By avoiding a DC connection, small perturbations can be observed even in very large static fields, and the problems associated with offsets and long term drift are avoided.

Body-electrophysiology sensing

The high impedance EPIC requires no direct electrical connection, so that electric potentials on the skin can be measured without any contact preparation. Simply grasping an EPIC sensor in each hand reproduces the conventional I-Lead electro-cardiogram (ECG) with diagnostic quality. Body surface potentials are sensed across the capacitor formed between the skin and the insulated input electrode of the sensor. The low input capacitance means that skin imperfections and hair do not impair measurement. Surface potentials may even be sensed through some thin fabrics and so the sensor is applicable not only to ECGs, but also to the EMG (electromyogram) and EOG (electro-oculogram), where the electrical signals due to muscular and eye movement are sensed respectively, opening up their use for prosthetic limb control, eye muscle movement detection to control a cursor, etc.

The sensors offer several advantages that save money and speed up taking readings. They are dry contact so that no gels or similar fluids are required to make contact and can be simply cleaned between uses - unlike conventional ECG sensors that have to be disposed of after every use at a cost of \$2 a set. The sensors also only need to be



Fig. 1: The PS25101 supplied in custom engineered, metal or plastic disc style, probe assembly with the control unit.

held in each hand, providing a quick and easy measurement. This ease of detection even through clothes or at a distance means that new ways of taking ECG measurements are being investigated by customers. For example, the sensors could be built into stretchers for immediate monitoring of patients heart rate and respiratory action or built into clothing to monitor stress levels in emergency response personnel such as firemen.

The low power opens up the opportunity for ECG monitoring over a long period of time so that abnormalities can be picked up during normal activities without the stress of being in a hospital or doctor's room. The ease with which body potentials are acquired means that the EPIC is not only applicable to conventional medical diagnostics, but also to new methods of human machine interaction. The monolithic EPIC sensor with an isolated electrode structure is easily integrated into a

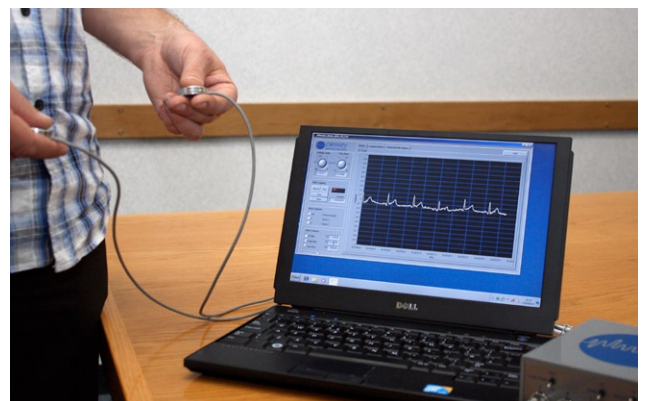

Fig. 2: The EPIC used for measuring heartbeats, is so sensitive that even the breathing pace can be detected as signal modulation. The same technology could be used as a low cost proximity sensor.

Phil Watson is a Research Assistant at the University of Sussex, UK - www.sussex.ac.uk

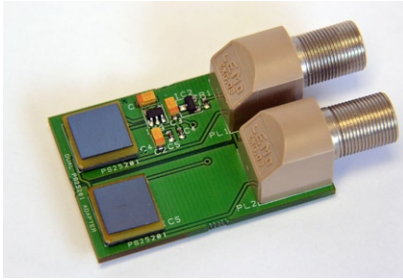

Fig. 3: The Electric Potential Integrated Circuit (EPIC) application boards with single and dual-channel sensors.

variety of applications, including hand-held battery powered devices.

The EPIC sensor is being offered in two package formats. The PS25101 is supplied in the same custom engineered, metal or plastic disc style, probe assembly that was used for the first prototype sensors and demonstration systems. This comes complete with a connecting lead and DIN plug termination. The PS25201 is an ultra-high 10x3mm impedance sensor supplied in a more compact custom package with four exposed balls for surface mount assembly onto the PCB of a customer's equipment design. The large coupling capacitance of the human body of around 250pF means the EPIC sensor can be used to obtain true ECG signals by detecting the potential at surface of the skin that is typically 1mV p-p. These sensors are designed for use in high reliability medical applications and, if required, can be built with an anodised titanium electrode. Application boards with single and

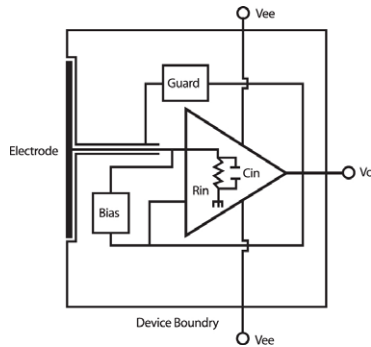

Fig. 4: The EPIC sensor diagram.

dual-channel sensors are available to assist with evaluating and prototyping.

Movement detection

EPIC allows passive movement sensing by detecting the perturbations made to the ambient electric field of around 100V/m. When a large earthed object moves, such as a human body, the resultant disturbance to the field is sensed, even through walls, making it suitable for applications ranging from security, to automotive, to safety through to gesture recognition applications. The gesture recognition capability has been picked up for controller-less gaming and the remote control of electronic consumer products like televisions, monitors and computers. The output signal of an EPIC is a voltage waveform which is proportional to the proximity to the moving body, and the nature of the movement. The use of multiple sensors dramatically expands the sensing possibilities; by distributing multiple sensors around a space position information can be inferred.

The EPIC movement sensor can be used in both proximity mode or to detect specific

kinds of movement as a limited gesture recognition device. As the sensor does not need line of sight and can even detect movement through walls, it can also be used to replace, or as an adjunct to, a passive infra-red (PIR) sensor in a variety of applications including security motion detectors. The base layout of the chip has been optimised such that discrete movements of the human body can be detected up to several metres. For example, the sensor can be configured to detect the proximity of a hand or to detect specific hand motions depending on the chip variant and the appropriate selection of circuit components external to the sensor.

Whilst these first applications for individual sensors are quite simple, they are paving the way for the next generation of sensor array devices that will change the way users address more sophisticated applications like writing on tablets and smart phones, the remote control of televisions and controller-less gaming applications.

The latest version of the sensor can be used in any electrical application as a simple switch including toys, electric appliances, smart lighting, gaming and security and is engineered for higher volume applications allowing volume prices for the chip solution of around \$1. This opens up a wide range of new applications around this new sensing technology. ■

High accuracy concept-study position sensor enables car2x applications

By Christoph Hammerschmidt

BY FUSING DRIVING DYNAMICS sensor information with GPS data, automotive supplier Continental will make it possible to determine the precise position of a vehicle within its lane. This degree of exactness is required to roll out car2x applications. Continental's M2XPro (Motion information 2 X Provider) sensor uses an intelligent fusion algorithm to provide control units inside and outside of the car with a vehicle's motion information together with a precise time base. The ability to determine the vehicle's position very exactly is essential for a number of applications, particularly for car2x communication.

To date, driving dynamics sensors and GPS lack sufficient precision and reliability

for car2x applications: GPS connection can be occasionally interrupted when crossing bridges or driving between high buildings. Many driving dynamics sensors, such as inertial sensors for acceleration and yaw rate, wheel speed sensors and steering angle sensors, are already in use in vehicles fitted with electronic stability control, allowing the vehicle's movements to be recorded and its relative position to be determined with great precision. Continental's sensor combines the data from these sensors with the GPS data which acts as an external reference for determining the vehicle's absolute position. The sensor fusion within the M2XPro checks the plausibility of all the vehicle's drive dynamics data and makes it available to other



control units. This redundancy improves the quality of the data generated. Since the M2XPro is designed so as to make use of the sensors installed in the vehicle and, in addition, to link up with the GPS data, it can be integrated into existing vehicle architectures.

At present, the sensor exists as a concept study for trialling in prototype vehicles. By 2015, the M2XPro will have been developed to the point that the sensor can be used in the first car2x systems. The M2XPro can then also be combined with the same vendor's intelligent antenna module, allowing precise vehicle data to be made available not only to all the vehicle's own systems but to be transmitted to the surrounding infrastructure as well. ■

USB measurement control units *for analogue & digital I/Os, digital counters*

The AIO-121602LN-USB and AIO-120802LN-USB from Contec are measurement control system architecture units which expand the feature of analogue I/O, digital I/O and digital counter to computers, through USB. These products have a plug and play function for USB that enables engineers to connect them to a PC. At 30.5mm thick, the modules are compact and designed to be mounted onto a 35mm DIN rail. They can also be installed anywhere with a rubber feet and magnet, or via 4 screw holes. Development tools are provided such as a Windows driver, a Visual Studio-compliant library, sample programs and the full-fledged data logger software, C-



LOGGER. The units can be used as DAQ devices for MATLAB or LabVIEW. The AIO-121602LN-USB features 16 channels of analogue input (12-bit), two output channels (12-bit), 16 channels of bi-directional digital I/O and one counter channel (32-bit). The AIO-120802LN-USB features 8 channels of analogue input (12-bit) with its other specifications identical to that of the AIO-121602LN-USB. The analogue I/O can be synchronized with an internal timer and a digital filter prevents erroneous input signal recognition from noise or chatter.

Contec

www.contec.com

8-channel data logger

can monitor alarm thresholds and digital outputs

The Microlink 840 from Biodata is a versatile 8-channel data logger which can also monitor alarm thresholds and output digital control signals. The unit is well suited for monitoring analogue transducers including pressure, temperature, force, voltage and current, monitoring digital sensors like flow meters; counting switch closures; counting items produced; monitoring machines to record percentage on/off times and logging data from utility meters. Windmill software makes it easy for users to configure the Microlink 840 and regularly download its data. Data can be saved as text, xml, EnergyLens files and to a MySQL database on the Internet or Ethernet network. Users can choose cus-



tom engineering units through software, scaling readings into the required units. Two alarms can be set on a combination of channels, and a digital channel switched when an alarm occurs.

Remote PCs can also be notified over Ethernet or Internet. Maximum, minimum, average and final values can be saved over the logging interval, which can be between 1 minute and 9 hours long. The logger can count totals, frequency, periods, pulse widths and elapsed time. Counting can proceed to over 16 million. The default voltage input range is 0-3.3 V, but this can be changed at the factory or by users.

Biodata

www.microlink.co.uk

Efficient optical beam sensor line *in M18 plastic housing*

Wenglor's new range of sensors, delivered in a plastic M18 housing, offers efficiency and a low cost installation, yet features a highly practical mechanical design available for straight and angled reflex sensors, retro-reflex sensors and through beam sensors with cable or plug. With housing lengths of 35mm (straight variant) and 50mm (angled variant), the photoelectronic sensors are very compact and can be integrated into any application. All of the modes of operation offered with the new sensor range are equipped with an antivalent output, a potentiometer for adjusting switching distance and two diagnosis LEDs. The



integrated LEDs indicate switching status, contamination and supply voltage, and are highly visible from any angle. Switching distance can be precisely adjusted to any application with the potentiometer which is protected against destruction due to over-twisting by means of a mechanical limit stop. The mounting system included as standard equipment with the sensors allows for easy attachment ranging from integration into the system right on up to quasi-flush mounting. The sensors can be fed through an opening and secured from either side. This simplifies and accelerates initial start-up, and reduces installation costs.

Wenglor

www.wenglor.com

Linear Hall sensor

now available in SMD package

Chip vendor Micronas announced the availability of its HAL 880 Hall sensor in SOIC8 package. This eliminates many cost adding processes, such as the leads bending process, often necessary for leaded packages such as the TO92. The HAL 880 in SOIC8 combines high performance sensor technology with a cost-effective, manufacturing friendly package, leading to attractive cost improvements at system level. The sensor is equipped with a linear analogue output and is particularly suitable for applications where linear movements (distance, position) have to be detected. The device uses a DSP to adapt the incoming magnetic field to the wanted output characteristic. Furthermore, the DSP compensates alterations of the

Hall voltage, caused by temperature fluctuations. Field strength variations of the magnet over temperature can also be compensated. It incorporates a push-pull 12-bit ratiometric analog output with less than 25 mV noise. Wire-break detection is featured to insure reliable sensing. All programming parameters are kept in the internal EEPROM, and there are 13 extra bits for customer or application specific data. Programming is done by modulating the supply current. Operating junction temperature range of -40 to +140 °C makes the HAL 880 suitable for industrial as well as for automotive applications.

Micronas

www.micronas.com

SPECIAL FOCUS: SENSORS & DATA CONVERSION

2D and 3D gestures recognition

software and database enable touchless control

Movea is making state of the art gesture recognition and gesture database design capabilities available to consumer electronic OEMs and systems integrators through its GestureBuilder software. Part of Movea's SmartMotion portfolio and a component of the MoveTV platform, GestureBuilder enables touchless gestures for control of smartphones, tablets, TV's, set-top-boxes, and media center PC's running Linux, Android, and Windows 7. Windows 8 support is also planned. GestureBuilder offers customers the capability to create an unlimited number of 2D and 3D gestures utilizing 2- to 9-axes of sensor data from any combination of MEMS ac-

celerometers, gyroscopes, and magnetometers. Additionally, consumer electronics OEM's and systems integrators can benefit from Movea's pre-defined libraries of 2D and 3D gestures, simple swipes, and predefined packages of custom gestures for vertical markets. GestureBuilder captures motion data from combinations of MEMS sensors and leverages Movea's extensive portfolio of proprietary data fusion and signal processing techniques to be able to record and recognize gestures in real-time and optimize gesture databases for performance and accuracy.

Movea

www.movea.com

Digital differential pressure sensors

down to 10Pa sensitivity, draw as little as 400µA

Sensirion's SDP6x6 sensor line features especially low energy consumption, making it suitable for long-term battery operation. The SDP606 and SDP616 sensors are designed to enter sleep mode after performing each measurement. They wake up when a "measure" command is received

and enter sleep mode again after completing the measurement. The operation currents of a standard SDP600 sensor can be high as 6mA, but the new SDP6x6 sensor is optimized for operating currents no greater than 400µA. There is virtually no current drain (<1 µA) in sleep mode. This drastic reduction in power consumption allows the new sensors to be used in battery powered applications. The sensors offer a digital I²C output and are fully calibrated and temperature compensated. Thanks to the principle of calorimetric flow measurement, CMOSens differential pressure sensors achieve outstanding sensitivity and accuracy even at very low pressure differences (< 10 Pa). Furthermore, they have very high long-term stability and are free from zero-point drift. Like all devices in SDP600 series, the new sensors are available in two different versions. The SDP606 is intended for direct threaded connection to a pressure manifold with O-ring sealing, while the SDP616 is designed for tube connection.

Sensirion

www.sensirion.com



and enter sleep mode again after completing the measurement. The operation currents of a standard SDP600 sensor can be high as 6mA, but the new SDP6x6 sensor is optimized for operating currents no greater than 400µA. There is virtually no current drain (<1 µA) in sleep mode. This drastic reduction in power consumption allows the

Silicon temperature sensor

high accuracy and resolution at up to +125°C

Microchip Technology has developed the MCP9808 silicon temperature sensor, which serves a broad range of applications by guaranteeing high

accuracy of 0.5 degrees from -20 to +100 °C, along with high temperature resolution of 12 bits (0.0625 °C/LSB). Many applications require high accuracy over a variety of temperatures, such as thermostats (-20 to +45 °C), personal computers (+85 °C) and industrial/automotive (+125 °C). With its extremely high accuracy levels over a wide temperature range, the MCP9808 is suited for all of these applications and more. Additionally, many applications can benefit from reduced energy usage via accurate temperature monitoring and control that enables more efficient operation. With its shutdown and temperature monitoring/alert features,

the MCP9808 can help adjust the real-time power utilization of everything from residential HVAC systems to industrial equipment. Specifically, its shutdown feature reduces power consumption in both line- and battery-powered systems. The on-chip over/under temperature monitor can improve system performance through thermal optimization. Finally, the MCP9808's critical-temperature alert can increase the system's life by preventing harmful operating temperatures. The MCP9808 comes in small MSOP and 2x3mm DFN 8-pin packages, for space-constrained applications. Additional features include shutdown, an under/over-temperature monitor and a critical-temperature alert.

Microchip Technology

www.microchip.com

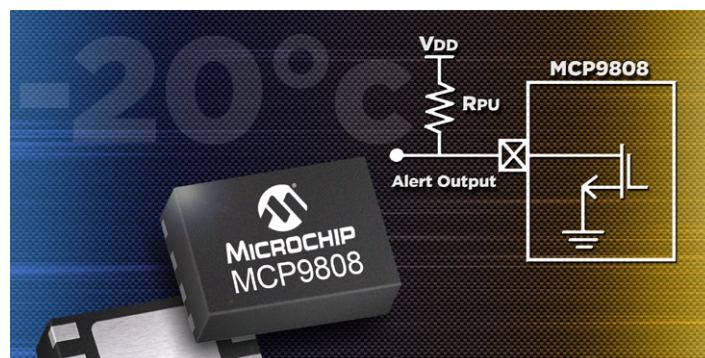

accuracy of 0.5 degrees from -20 to +100 °C, along with high temperature resolution of 12 bits (0.0625 °C/LSB). Many applications require high accuracy over a variety of temperatures, such as thermostats (-20 to +45 °C), personal computers (+85 °C) and industrial/automotive (+125 °C). With its extremely high accuracy levels over a wide temperature range, the MCP9808 is suited for all of these applications and more. Additionally, many applications can benefit from reduced energy usage via accurate temperature monitoring and control that enables more efficient operation. With its shutdown and temperature monitoring/alert features,

sonitron[®]

Piezo audio components

Buzzers Transducers Alarms

Sirens Piezo Speakers Amplifiers

Photoelectric sensor for clear objects *has a response speed of 250 microseconds*

Banner Engineering's Q26 Series photoelectric sensor features a polarized retro coaxial design, providing reliable detection of clear, translucent or opaque objects, including mirror-like surfaces. With the ability to operate at very short distances, the Q26 is suitable for detection applications such as filling and bottling machines, flat glass or LCD manufacturing, pharmaceutical vials or bag filling machines, or any high-speed application where positioning is critical. The Q26 comes as a compact cubic unit with 20mm mounting hole spacing, enabling quick installation in tight locations. The sensor's coaxial optics permit operation over a wide range of distances with the reflector

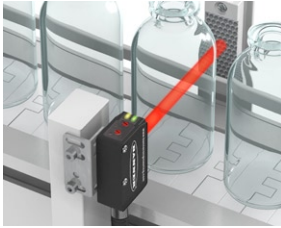

tor mounted as close as 5 mm for applications with restricted spaces. The Q26 includes a LO/DO switch to control the output type, and a single turn potentiometer to adjust detection sensitivity. Equipped with a Health Mode output for application monitoring, the Q26 communicates operation and connection status—allowing the user to ensure reliable sensor performance. The sensor operates on 12-30V dc with a response speed of 250 microseconds. It is protected against damage from potential mis-wiring during installation and transient voltage spikes during operation.

Banner Engineering

www.bannerengineering.com

Digital color sensors

with on-chip IR filtering and proximity sensing

TAOS has launched what the company claims to be the industry's first color sensors with an on-chip infrared (IR) blocking filter and proximity sensor. The TCS3x71 and TCS3x72 Series provide color measurement, and when coupled with IR LED, proximity detection within a wide range of lighting conditions and through a variety of attenuating materials. The TCS3x72 Series' IR blocking filter is integrated directly on-chip and localized only to the color sensor photodiodes. High accuracy color sensing requires eliminating errors due to the IR spectral component in light sources. The on-chip IR blocking filter minimizes these effects and eliminates requirements for external IR filtering. In addition, the on-chip IR blocking filter enables the devices to perform ambient light sensing to enable automatic backlight brightness control based

on ambient lighting conditions. The TCS3x71 Series applications include closed-loop color temperature feedback control in solid-state lighting (SSL) and LED RGB backlit displays. The combined color and proximity sensing in the TCS3771 and TCS3772 family of devices has applications in OLED-based smartphones for determining the color temperature of the ambient light to provide the optimum display picture quality and to provide touchscreen control. These devices can also be used to create smarter products, such as household appliances, which sense color and user presence. The TCS3x71 and TCS3x72 Series is pin and register compatible enabling simple design options and minimizing software development.

TAOS

www.taosinc.com

Airbag sensors

couple crash detection with in-vehicle communication

The Xtrinsic MMA65xxKW family of automotive acceleration sensors from Freescale Semiconductor are designed to speed the development of advanced airbag systems that help save lives and protect against injuries caused by vehicle collisions. The accelerometers employ intelligent sensing technologies designed for front and side crash detection that can be easily and efficiently integrated into vehicle airbag systems. The MMA65xxKW family is based on high-aspect-ratio micro-electromechanical systems (HARMEMS) technology. The family offers better resolution (precision) and a wider dynamic range than competing solutions on the market today, resulting in higher performance capabilities. Featuring a robust, streamlined in-vehicle communication system, the MMA65xxKW family has sophisticated crash detection capabilities that enable fast and dependable deployment of the total passive safety system when collisions are unavoidable. Freescale's MMA65xxKW accelerometers are the safing sensors located in the vehicle's main electronic control unit (ECU) if the airbag system uses satellite

sensors. Satellite inertial sensors (Freescale's MMA5xxxKW) are positioned around the perimeter of the car to detect front and side impacts. Working together, these sensors assist the vehicle in determining the optimal deployment of the airbags. The MMA65xxKW sensors work at 105 g-range and a 12-bit data output with 18.2 LSB/g, enabling improved sensor resolution with no programming necessary by the manufacturer and wider dynamic range measurement capabilities required for smaller vehicles. Compatible with a standard serial peripheral interface (SPI) protocol, the sensors can be easily incorporated into an airbag system. They feature an arming pin function that reduces the risk of data corruption in the main crash sensor or safing sensor of the airbag system. The MMA65xxKW family incorporates either a single- or dual-axis over-damped lateral inertial sensor housed in a quad flat no-lead (QFN) package, which is designed for a smaller footprint and more flexibility for module orientation in vehicles.

Freescale Semiconductor

www.freescale.com

Wireless measurement system

analyses motion data remotely

Seiko Epson has developed the M-Tracer, a sophisticated yet easy-to-use wireless motion measurement system that can be attached to a person or object to gather and analyse motion data from sports and other activities. The M-Tracer is a self-contained system that combines a highly accurate and stable Epson inertial measurement unit (IMU) with analytical

3D visualization software that processes kinetic motion data captured by the IMU. In addition to human motion analysis, the M-Tracer can be used to measure and analyse the motion of industrial equipment. Development samples will

start shipping in early 2012.

Seiko Epson

www.epson-electronics.de

2.4 GHz RF smart remote

A complete hardware and software reference design featuring a multi-touch touchpad, 6-axis motion sensing, and full QWERTY keyboard, the nRFready 2.4 GHz RF Smart Remote leverages Nordic's nRF24L series SoCs and Gazell 2.4 GHz RF protocol stack to provide a feature-rich platform for devel-



oping remote controls for the latest Internet-enabled and Web 2.0 digital TV and set-top boxes. The reference

design includes native support for a multi-gesture TouchPad, QWERTY keyboard, and motion control that all combine to deliver a rich, intuitive, and engaging end-user experience for advanced control and browsing of all types of modern digital content and services including audio, video, gaming, web browsing, social media, and online shopping. Originally designed for PC peripherals, this radio and protocol combination delivers the bandwidth, latency, and co-existence performance necessary to seamlessly support all the nRFready RF Smart Remote's advanced features.

Nordic

www.nordicsemi.com

8051 CPU core is 56.8 times faster

IP Core provider Digital Core Design has unveiled its DQ80251 core, what the company claims to be the world's fastest 8051

microprocessor. A quad-pipelined ultra-high performance IP core, the DQ80251 runs at 300MHz thanks to its unique architecture. The core provides up to 0.54311 DMIPS/MHz (VAX MIPS) and uses only 14 500 ASIC gates. The DQ80251 family is available as VERILOG Source code, VHDL Source code and FPGA Netlist formats. The same IP cores are designed in a wide variety of additional packaging and flexible licensing options.

Digital Core Design

www.dcd.pl

Mechanical energy converters

EnOcean's ECO 200 third generation mechanical energy converters, combined with the PTM 330 transmitter module result in an entire system for batteryless wireless operations. EnOcean's batteryless wireless technology harvests energy entirely from its surroundings – from light, differences in



temperature or motion. Mechanical energy converters, for instance, can produce the energy needed to transmit a wireless signal just

from the press of a button. The batteryless PTM 330 wireless module can be connected to the energy converter by spring contacts, with no soldering. This wireless module features four digital inputs to map up to four switching states.

EnOcean

www.enocean.com

Temperature-compensating attenuators

The RFSA4013 and RFSA4023 from RFMD are fully monolithic analog Temperature-Compensating Attenuators (TCAs) featuring exceptional linearity over their entire gain control range. The RFSA4013 and RFSA4023 only require a single supply voltage and two logic bits to set the control attenuation slope

versus temperature. Each TCA draws a low 1 mA current and is packaged in a small 3x3mm

QFN. These attenuators are internally matched to 50 Ω over their rated control range and frequency. The TCAs cover a broadband 50 MHz to 4000 MHz frequency range with three selectable attenuation slopes versus temperature, IIP3 of +55 dBm, IIP2 of +85 dBm, and PrdB of over +30 dBm. Typical applications include cellular and 3G infrastructure, WiBro, WiMax, LTE, microwave radio and high-linearity level control.

RFMD

www.rfmd.com



1.4 MBytes/sec Download

Emulator (J-Link™)

ARM/Cortex™ and Renesas RX

- Fastest Emulator Available
- Extremely Fast Flash Download
- Intelligence Inside the Emulator for Robust Communication
- Multicore Debugging Support
- Supported by All Popular IDEs Including CodeBench, CodeWarrior, HEW, IAR, Keil, Rowley, and GDB/RDI Compliant Environments



8.16.00 J-Link ULTRA

1.4 MBytes/sec Download Speed
The Fastest J-Link Debug Probe Yet!

The J-Link can be coupled with a number of available software modules to fit your application needs.

J-Flash is a standalone application used with the J-Link to program internal and external flash devices.

J-Link Flash Breakpoint permits you to set an unlimited number of software breakpoints while debugging in flash.

As the original manufacturer of the J-Link and its OEM derivatives, we are happy to inform you that this software also supports the DIGI® JTAG Link, Atmel® SAM-ICE, and IAR® J-Link KS.



49.98€

Special Offer

8.08.90 J-Link EDU
Educational Use J-Link
Includes Flash Breakpoints
Includes J-Link GDB Server
www.segger-us.com/edu.html

J-Link Educational Use (EDU) Bundle

www.segger.com

2.4 GHz RF smart remote

targets TVs and set-top boxes

A complete hardware and software reference design featuring a multi-touch touchpad, 6-axis motion sensing, and full QWERTY keyboard, the nRFready 2.4 GHz RF Smart Remote leverages Nordic's nRF24L series SoCs and Gazell 2.4 GHz RF protocol stack to provide a feature-rich platform for developing remote controls for the latest Internet-enabled and Web 2.0 digital TV and set-top boxes. The reference design includes native support for a multi-gesture TouchPad, QWERTY keyboard, and motion control that all combine to deliver a rich, intuitive, and engaging end-user experience for advanced control and browsing of all types of modern digital content and services including audio, video, gaming, web browsing, social media, and



online shopping. The nRFready 2.4 GHz RF remote control features a multi-touch enabled TouchPad from Synaptics, a miniaturized QWERTY keyboard, a 6-axis motion sensing solution from Invensense, an ultra low power accelerometer from STMicroelectronics. The combination of Nordic's nRF24LE1 SoC and Gazell 2.4GHz RF protocol stack also ensures a high performance, ultra low power, and cost efficient remote control implementation. Originally designed for PC peripherals, this radio and protocol combination delivers the bandwidth, latency, and co-existence performance necessary to seamlessly support all the nRFready RF Smart Remote's advanced features.

Nordic

www.nordicsemi.com

8051 CPU core up to 56.8 times faster

than original 8051 at the same clock frequency

IP Core provider Digital Core Design has unveiled its DQ80251 core, what the company claims to be the world's fastest 8051 microprocessor. According to Digital Core Design, tests run on a Dhrystone 2.1 benchmark program have shown that the IP core is up to 56.8 times faster than the original 8051 at the same clock frequency. A quad-pipelined ultra-high performance IP core, the DQ80251 runs at 300MHz thanks to its unique architecture. The core provides up to 0.54311 DMIPS/MHz (VAX MIPS) and uses only 14 500 ASIC gates. These unique features

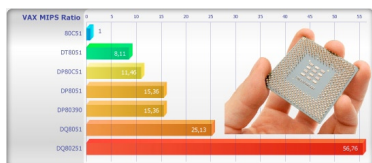

make the DQ80251 core suitable for all embedded applications demanding cost effective and best possible solutions. The DQ80251 family comes with an efficient real-time JTAG based DoCD debugger and is fully user configurable to be tailored to exact specifications. The DQ80251 family is available as VERILOG Source code, VHDL Source code and FPGA Netlist formats. The same IP cores are designed in a wide variety of additional packaging and flexible licensing options.

Digital Core Design

www.dcd.pl

Mechanical energy converters

pair up with wireless technology

EnOcean's ECO 200 third generation mechanical energy converters, combined with the PTM 330 transmitter module result in an entire system for batteryless wireless operations. This pairing creates an optimum basis for speedy and simple implementation of energy harvesting switching solutions. EnOcean's batteryless wireless technology harvests energy entirely from its surroundings – from light, differences in temperature or motion. Mechanical energy converters, for instance, can produce the energy needed to transmit a wireless signal just from the press of a button. The magnetic flux is suddenly reversed by a coil as soon as a spring mecha-



nism reaches a snap-over point. The batteryless PTM 330 wireless module can be connected to the energy converter by spring contacts, with no soldering. This wireless module features four digital inputs to map up to four switching states. The PTM 330 has a unique 32-bit identification number to eliminate any overlap with other wireless sensors. Wireless range is up to 30 metres inside buildings and 300 metres in the open. With versions for both 868 MHz and 315 MHz the module is suitable for applications worldwide.

EnOcean

www.enocean.com

Temperature-compensating attenuators

deliver high linearity

The RFSA4013 and RFSA4023 from RFMD are fully monolithic analog Temperature-Compensating Attenuators (TCAs) featuring exceptional linearity over their entire gain control range. These TCAs are designed to offset the gain reduction of an RF component over temperature without the need for closed loop feedback. Three customer selectable temperature coefficients make these TCAs a flexible solution for RF lineups. Each attenuator incorporates a circuit architecture that solves a longstanding industry problem with regards to attenuator architecture: high IP3, low DC current, and broad bandwidth. Traditional approaches for linear temperature-compensating devices require expensive co-fired ceramics with temperature-sensitive materials or current-hungry

PIN diodes with elaborate area consuming control circuits. The RFSA4013 and RFSA4023 only require a single supply voltage and two logic bits to set the control attenuation slope versus temperature. Each TCA draws a low 1 mA current and is packaged in a small 3x3mm QFN. These attenuators are internally matched to 50 Ω over their rated control range and frequency. The TCAs cover a broadband 50 MHz to 4000 MHz frequency range with three selectable attenuation slopes versus temperature, IIP3 of +55 dBm, IIP2 of +85 dBm, and P1dB of over +30 dBm. Typical applications include cellular and 3G infrastructure, WiBro, WiMax, LTE, microwave radio and high-linearity level control.

RFMD

www.rfmd.com

900 MHz wireless module outputs up to 24 dBm conducted

Laird Technologies has released the high power LT1110 900 MHz wireless module, based on proprietary FlexRF technology, which offers more than forty times the output power of the current low power LT1110. Embedded with the company's robust server-client protocol, the LT1110 family permits an unlimited number of clients to synchronize to a single server for low latency communications. The server and all clients in a network can communicate with any radio in range via either addressed or broadcast packets. The configuration and test software allows OEMs to design and test networks to suit their applications. The module features a higher output power, up to 24 dBm conducted, in the

same small surface mount or pluggable form factor as the original LT1110. It also includes an integrated antenna or U.FL for an external antenna. Easy-to-use with a quick time to integrate, the module provides simple wireless communications for point-to-point and point-to-multipoint networks. While the new High Power LT1110 offers greater transmit power than the previous Low Power LT1110 version, the same low power sleep modes are available, making the module a suitable product solution for the M2M market segment, particularly sensors and handheld data loggers.

Laird Technologies

www.lairdtech.com

Hard IP in FPGA

brings high speed SERDES into the mainstream

A new family of FPGAs from Lattice Semiconductor aims to bring high speed, 6Gbit/s SERDES into the mainstream with low cost devices. The 65nm Lattice ECP4 family uses low cost wire-bond packages and adds DSP Blocks and hard IP-

based Communication Engines for cost- and power-sensitive wireless, wireline, video, and computing

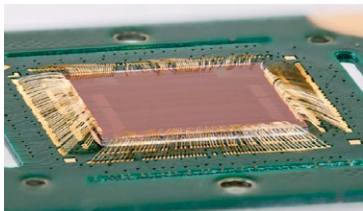

markets. It is aimed at developing mainstream platforms for a variety of applications such as remote wireless radio heads, distributed antenna systems, cellular basestations, Ethernet aggregation, switching, routing, industrial networking, video signal processing, video and data centre system.

The ECP4 contains up to sixteen CEI-compliant 6 Gbps SERDES channels with embed-

ded Physical Coding Sub-layer (PCS) blocks in both low cost wire-bonded and high performance flip chip packages for chip to chip as well as long haul backplane applications. The configurable SERDES/PCS can be integrated with the hardened

Communication Engines to economically build complete high bandwidth sub-systems with up to 10 times the power and cost reduction of similar implementations in FPGA fabrics. The LatticeECP4 Communication Engines portfolio includes solutions for PCI Express 2.1, multiple 10 Gigabit Ethernet MAC and Tri-speed Ethernet MACs as well as Serial Rapid I/O (SRIO) 2.1.

Lattice Semiconductor

www.latticesemi.com

4 plug computer kits to win

for your cloud computing or media streaming applications



This month, Marvell is giving away four D2Plug development kits, version 1.0 to set up a plug computer for your

cloud computing or media streaming applications. Worth \$249, the unit features the Marvell's Armada 510, a high-performance, highly integrated, low-power system-on-chip with an ARM v6/v7-compliant superscalar processor core. The D2Plug extends server applications to run with a larger memory footprint, and features integrated 2D and 3D graphics, dual-display HDMI/VGA output, hardware accelerated video decoding, and audio. Consuming fewer than 5 watts of power, and with a rich set of connectors for network-



ing and storage expansion, the D2Plug comes ready with a 1GB DDR3-800 x32 bus, one Ethernet 10/100/1000 Mbps port, two USB 2.0 host ports, one powered eSATA & USB 2.0 host combo port, a USB 2.0 device port, one SD card slot, and one HDMI 1080p output port with CEC. Other ports include a VGA output, an audio line output, one MIC input, an S/PDIF optical output, one console port (USB) and one JTAG connector. The computer comes with integrated 802.11 b/g/n Wi-Fi and Bluetooth v3.0 + HS. Except for power, all the interfaces are located on the sides of the main unit.

Marvell

Check the reader offer online at www.electronics-eetimes.com
www.marvell.com

Thermo-generator integrated unit outputs from 100µW with a 5°C gradient

Micropelt has launched a compact thermo-generator package (TGP), which makes thermal energy harvesting ready for mass production. The device allows for automatic assembly of autonomous DC power supplies for ultra-low power wireless sensors and

actuators. Whenever a temperature difference of 5°C or more is available, the output power ranges from 100 microwatts to over 10 milliwatts, sufficient to offset most batteries. Micropelt's standardized TGP package comes in two flavours, TGP-651 and TGP-751, both types being fully interchangeable. Output power and cost can thus be matched to target applications and markets without any changes to the PCB design. At lower

gradients, between 10 and 40 °C, both devices produce very similar power levels, so the TGP-651 with a 6mm² TEG is more cost-effective. Though, for very low gradient operation or high power demand a TGP-751, with a footprint of 12mm² is preferable.

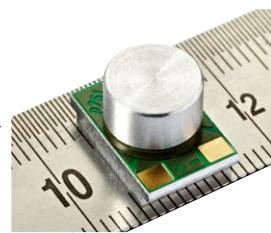

The TGP's circular aluminium heat source interface feeds through a 10mm hole of the hosting PCB. The rectangular cold face carries the electrical contacts for reflow soldering and connects to the heat sink on its outer side. The device's vertical dimensions ensure sufficient clearance for electronic components mounted next to it, underneath the heat sink.

Micropelt

www.micropelt.com

Low-cost RF plug-in

for the LaunchPad development kit

Texas Instruments has launched a sub-1 GHz radio frequency (RF) low cost plug-in-board for its MSP430 microcontroller LaunchPad development kit. The 430BOOST-CC110L RF BoosterPack includes ETSI-compliant and FCC-certified modules to help speed development time, reduce certification costs and

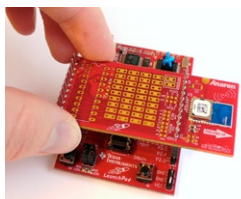

eliminate barriers associated with the RF hardware design process. The RF BoosterPack contains two plug-in-boards with RF

modules integrating TI's CC110L sub-1 GHz RF transceiver, passive components and compact PCB antenna, along with a CD with software and documentation. It also includes a wireless software stack from TI partner Anaren to make it easy for developers to add RF to any system. The key to the pack is that no RF hardware design is required.

Texas Instruments

www.ti.com

Power modules

for single-phase solar inverters

Vincotech has added three new products to the company's family of power modules for single-phase solar inverter and UPS applications. The additions to Vincotech's series of flowSOL o power modules meet the latest demands of single-phase solar inverter and UPS inverter applications. Featuring a booster



and inverter (H-bridge) in the same flow housing, they are rated for 1.5 kW to 5 kW.

Engineered especially for transformer-less

600 V solar- and UPS applications, the new modules leverage the latest Infineon CoolMOS C6 technology and SiC diodes to deliver superior performance and satisfy high demands for efficiency (up to 98%).

The modules are packaged in Vincotech's standard flow o 2-clip housing measuring 66 mm by 33 and 12mm in height. The modules are in serial production and samples are available now.

Vincotech

www.vincotech.com

From 2D to 3D

sketching intuitively

Dassault Systèmes has released CATIA Natural Sketch, a tool that brings together the intuitiveness of creative 2D painting gestures and the power of accurate, realistic 3D modelling. This first-of-its-kind, lifelike creative experience helps designers to free up their creativity and share their ideas more rapidly



and precisely. CATIA Natural Sketch also eliminates workflow disruptions through the entire industrial

design process. The tool avoids misinterpretations of 2D views and gives designers and design studio teams the ability to use 3D sketched curves to create a model with surface modelling or subdivision surface modelling tools within CATIA. By directly transforming a 2D sketch into a 3D digital product, inconsistencies between the design intent and reality can be avoided, resulting in dramatic improvements in design quality.

Dassault Systèmes

www.3ds.com/ukisa

GPRS IP gateway

switches to available channels

Advantech's EKI-1321 and 1322 GPRS units have been designed to ensure that networks are always connected. With dual SIM slots, designed to support GPRS signal redundancy which automatically switch to any available channel if the other one is disconnected and an SD slot for data buffering and auto recovery to prevent loss of serial data if the communication is interrupted the EKI-1321 and 1322 always provide reliable and redundant communication. The EKI-1321 and EKI-1322 are cellular gateways that can transparently bring RS-232/422/485 or Ethernet devices to a cellular network. They allow nearly any device with serial or Ethernet ports to connect and share a cellular network with an easy and simple configuration. The units can be DIN-rail or wall mounted; coming with both front panel and side panel LED displays for easy identification.



Advantech

www.advantech.eu

PICO

Surface Mount (and Plug In) Transformers and Inductors

See Pico's full Catalog immediately
www.picoelectronics.com

Low Profile from
.19" ht.



Audio Transformers

Impedance Levels 10 ohms to 250k ohms, Power Levels to 3 Watts, Frequency Response ± 3 db 20Hz to 250Hz. All units manufactured and tested to MIL-PRF-27. QPL Units available.

Power & EMI Inductors

Ideal for Noise, Spike and Power Filtering Applications in Power Supplies, DC-DC Converters and Switching Regulators

Pulse Transformers

10 Nanoseconds to 100 Microseconds. ET Rating to 150 Volt Microsecond, Manufactured and tested to MIL-PRF-21038.

Multiplex Data Bus Pulse Transformers

Plug-In units meet the requirements of QPL-MIL-PRF 21038/27. Surface units are electrical equivalents of QPL-MIL-PRF 21038/27.

DC-DC Converter Transformers

Input voltages of 5V, 12V, 24V And 48V. Standard Output Voltages to 300V (Special voltages can be supplied). Can be used as self saturating or linear switching applications. All units manufactured and tested to MIL-PRF-27.

400Hz/800Hz Power Transformers

0.4 Watts to 150 Watts. Secondary Voltages 5V to 300V. Units manufactured to MIL-PRF-27 Grade 5, Class S (Class V, 155°C available).

Delivery-Stock to one week
for sample quantities



PICO Electronics, Inc.

143 Sparks Ave. Pelham, N.Y. 10803
E Mail: info@picoelectronics.com
www.picoelectronics.com

Pico Representatives

Germany

ELBV/Electroniche Bauelemente Vertrieb

E mail: info@elbv.de

Phone: 0049 (0)89 4602852

Fax: 0049 (0)89 46205442

England

Ginsbury Electronics Ltd.

E-mail: rbennett@ginsbury.co.uk

Phone: 0044 1634 298900

Fax: 0044 1634 290904

Energy harvesting subsystems

fit to plumbing installations

Nextreme Thermal Solutions has developed two new energy harvesting subsystems for the plumbing and HVAC industries. The subsystems use the company's thin-film Thermobility thermoelectric technology to convert available thermal energy into electric power for a variety of autonomous self-powered applications. Thermobility uses differences in temperature to enable power anywhere there is an adequate heat source. The technology eliminates the need to use traditional wired power sources or replaceable batteries. When paired with wireless transmitters, the Thermobility solution can provide electric power for years of maintenance-free operation, thus expanding the possibilities for new wireless sensor applications in plumb-



ing, HVAC, industrial control, transportation, automotive and building management. Thermobility is the ideal power source for wireless transmission applications. Water in plumbing fixtures provides an excellent source of thermal energy for a variety of "green plumbing" applications. Thermal energy from water supply lines under a sink and during flush valve

operations can be converted to electricity as a source of power for LED status indicators, hands-free faucets, soap dispenser solenoids, and wireless transmitters for data acquisition applications. Harvested power can help reduce the size of batteries or eliminate them entirely depending on the application.

Nextreme Thermal Solutions

www.nextreme.com

SuperTube LED light

replaces overhead fluorescent lighting

PowerSecure International has introduced an energy efficient LED-based light, designed to replace and upgrade commercial overhead T8 and T12 fluorescent lighting. This SuperTube technology is market ready; first installation of SuperTubes and power drivers have been completed. According to the company, the first SuperTube installation instantly and significantly improved the energy efficiency and quality of light in the user facility where it has been installed. The SuperTube is designed for indoor T8 and T12 retrofit applications, and to deliver strong returns on investment for

customers installing the lights. They are engineered to deliver up to 75% energy savings compared to fluorescent lighting, and improve the quality of light in the workplace. They are also designed to significantly reduce maintenance cost, due to their long light life of approximately ten years which would require the utilization of four fluorescents over the same period. Importantly, the lights are easy to retrofit, which keeps the cost of installation low, and enables customers to complete energy efficiency projects expeditiously.

PowerSecure International

www.powersecure.com

All-in-one embedded SBC

with a 100x72mm footprint for space-saving design

With the MIO-2260 Data Modul presents an all-in-one ultra-small size embedded Single Board Computer (SBC) in a 100x72mm footprint, easy to integrate into space-limited systems, making it a good fit for power saving environments. The MIO-2260 is designed with the Intel Atom N455 single core processor and DDR3 memory support up to 2GB DDR3 SO-DIMM.

It provides flexible modular design capability for customers through its innovative MIO extension interface (MIOe) which includes compatibility

for 4 x PCIe x1, 3 x USB 2.0, audio line-out, SMBus and LPC, as well as 5Vsb, 12Vsb and power control signal. MIOe modules can be completely customized



to meet customer's requirements. TFT Displays can be controlled by single channel 18 bit LVDS. The unit features one VGA output and

supports dual-display configurations. The MIO-2260 has multiple applications in small HMI, embedded handheld devices, medical and intelligent home automation.

Data Modul

www.data-modul.com

NXP reveals ARM Cortex-M0 MCUs

with integrated USB drivers

NXP Semiconductors N.V., has introduced the LPC11U2x series – the first microcontroller based on the ARM Cortex-M0 processor to offer integrated USB class drivers. By integrating multiple USB drivers in ROM, the LPC11U2x maximizes Flash memory utilization, saving up to 16 KB of code space while providing fully tested and easy-to-use APIs to enable



USB integration in a matter of minutes. With up to 128 KB Flash and up to 4K EEPROM, the NXP LPC11U00 family of microcontrollers is designed for consumer, industrial, handheld and computing applications. NXP is also starting a global program in which it will sub-license its USB Vendor ID (VID) and offer Product ID (PID) numbers free of charge to MCU customers. To make USB

development on Cortex-M0 even easier, NXP and ARM is also expanding mbed, the popular rapid prototyping tool platform, to include LPC11U2x. The extensible on-chip USB drivers include Human Interface Device (HID), Mass Storage Device Class (MSC), and Communication Device Class (CDC). The driver capability can be further enhanced by NXP's fully featured open source USB library

available on www.lpcware.com. Complementing the Cortex-M0 core, the on-chip 32-bit Divide library provides deterministic cycle time execution while executing from low-power ROM. The LPC11U00 family also offers on-chip power profiles which can be customized for any low-power application.

NXP Semiconductors

www.nxp.com

Lighting design tools
simplify LED design online

Arrow Electronics has announced an application platform that enables engineers to design complete LED lighting solutions in a convenient online environment. The Arrow Lighting Designer offers tools and solutions tailored to customers' applications, with built-in design guidelines providing quick results. The Light-



ing Designer platform combines multiple tools for selecting and optimizing LED solutions, adding

secondary optics, defining the power supply and selecting and laying out a design. Each tool can be used independently to design and analyze individual components, or in tandem to develop a comprehensive solution. In addition to valuable LED product and system data, the tool offers several LED system options, such as the "recommended," "highest efficacy" and "least expensive" solutions.

Arrow Electronics

www.arroweurope.com

Pan-European deal
signed between Avnet and Murata

Avnet Abacus has signed a Pan-European franchise agreement with Murata covering the Japanese manufacturer's broad range of innovative passive products. The agreement builds on a 20 year relationship between the two companies. Previously, Avnet Abacus has covered selected European territories for Murata passives and has held a Pan-European agreement for the company's power solutions products. This extended agreement further enhances Avnet Abacus' position as a leading distributor of Murata products. Avnet Abacus is particularly enthusiastic about introducing Murata's innovative ceramic based components to a wider European design engineering audience. Commented Alan Jermyn, VP European Marketing: "We recognise Murata's global leadership in ceramic based electronic components. Our particular focus will be on the application and design in of new products such as SMD Pyroelectric Infra Red sensors, AMR Sensors, Microblower, timing devices & Metal T-cap ranges."

Avnet Abacus

www.avnet-abacus.eu

19.9mm thin sounder
delivers 87dB at 1m

Motion29 has introduced Patlite's super skinny MP3 voice annunciator, the BSV model with a depth of just 19.9mm, nearly 80% slimmer than the BDV model. Despite its slim build, a maximum sound of 87 dB (at 1m) can be reached in normal operation mode. The sound reduction function (recommended



for night time use, while on standby, etc) allows the operator to have full control by reducing the volume from between -1 and -50dB in line with environmental conditions. Volume adjustment is easily accessible from the front panel, and a low power of 3.5W (max) takes an extra load off the power supply. An SD card slot is incorporated into the unit to allow messages to be written and re-written and the Patlite Playlist Editor software (free to download) allows messages to be added or edited with ease – no prior programming knowledge required.

Motion

www.motion29.co.uk

DesignSpark chipKIT
global challenge is open

RS Components has launched the DesignSpark chipKIT Challenge, a global online competition that challenges electronics design engineers, students and hobbyists to produce an energy-efficient, eco-friendly design. Entrants will use the award-winning, free-of-charge DesignSpark PCB software tool from



RS and the Digilent chipKIT Max32 development platform featuring the 32-bit PIC32 microcontroller from Microchip Technology, a leading provider of microcontroller, analogue and Flash-IP solutions, to realise their designs. Registration for the chipKIT Challenge will open at www.chipkitchallenge.com, with participants invited to submit design projects showcasing the functionality of the chipKIT Max32 development kit and DesignSpark PCB in an environmentally-friendly application. The first 1,000 qualified entrants to register will be eligible to receive a complimentary chipKIT Max32 development board.

RS Components

www.rs-components.com

PICO

New High Voltage
Up to 500 VDC
Hi Power
Up to 50 Watts
Regulated DC-DC Converters



Miniaturized Size Package:

2.5" X 1.55" X 0.50"

High Voltage, Isolated Outputs
100-500 VDC

Low Voltage Isolated Outputs
5-48VDC also Standard

Output Voltages from 500VDC
High Power: to 50 Watts,
Efficiency to 90%

5, 12, 24, Wide Input Ranges

Consult Factory for Special Input Voltages

Safe: Short Circuit, Over/Under Voltage, and Over Temp. Protected

Options Available: Expanded Operating Temperature, -55°C to +85°C Environmental Screening, Selected from MIL Std.883

Ruggedized for Operation in Harsh Environments

External Bias Control: For Charge Pump Applications

Custom Modules: Available to optimize your designs, Special Input or Output Voltages Available

PICO's QP Series compliments our 650 plus existing standard High Voltage Modules. Isolated, Regulated, Programmable, COTS and Custom Modules available, to 10,000 VDC and other High Voltage to 150 Watts!

Pico Representatives

Germany

ELBV/Electra Bauemente Vertrieb
E-mail: info@elbv.de

England

Ginsbury Electronics Ltd
E-mail: rbennett@ginsbury.co.uk

www.picoelectronics.com
E-Mail: info@picoelectronics.com

PICO FAX 914-738-8225
Electronics, Inc.

143 Sparks Ave, Pelham, NY 10803-1837

Amplifiers are the hidden heroes of any system

By Steve Sockolov

WE OFTEN TAKE FOR granted that amplifiers can handle any input signal voltage ranging from microvolts to beyond the power supplies, operate on almost any voltage, and output a signal that can drive the following stage.

At the same time, the amplifier must protect the system from anything that could be connected to the input purposely or accidentally. They might not be as sexy as the latest MEMS gyro or A/D converter, but amplifiers perform real and necessary functions in most electronic systems. Because of this near ubiquity, they are particularly good bellwethers of industry trends. Two key trends that have been steadily growing for years, and are poised to gain significant momentum in 2012, are the migration towards zero-drift capability and the much-greater range of voltages that will be seen at the supplies and the inputs.

Operational amplifiers, among the most widely used components, can be found in virtually all types of systems. They are an essential building block for functions such as filters and instrumentation amplifiers. Each function requires specialized performance, causing the evolution of many performance parameters or features to suit various applications. Op amps may be selected for speed, noise (voltage, current, or both), input offset voltage and drift, bias-current, and common-mode range. Other factors include power output, ambient temperature range, supply voltage, and packaging.

The continued migration of configurations and functionality, from single amplifiers into functional blocks, has created many different categories of amplifiers, enabling higher performance and simplifying the design process. Even more than before, op amps are becoming the “proving ground” for many of the features and functions that are later designed into specialty amps.

These high-performance devices, which include instrumentation amps, current-sense amps, differential amps, and program-

mable-gain amps, are designed for specific signal types, and extract and amplify the signal of interest. These different classes of amps perform a variety of functions, including capturing and filtering low-level ac signals, providing automatic gain and converting picoamps of current to precision voltage signals.



“Today’s zero-drift amplifiers dynamically correct offset voltage and reshape noise density as well.”

Zero-drift amplifiers exemplify this trend. A technique originally developed to address constantly changing temperature as well as drift over time, today’s zero-drift amplifiers dynamically correct offset voltage and reshape noise density as well. Zero-drift amplifiers were originally used in systems with an expected design life of greater than 10 years, and in signal chains that use high closed-loop gains (>100) with low-frequency (<100 Hz), low-amplitude signals. Examples can be found in precision weigh scales, medical instrumentation, precision metrology equipment, and infrared, bridge, and thermopile sensor interfaces.

In addition, zero-drift amplifiers have nearly zero offset, and higher open-loop gain, power-supply rejection, and common-mode rejection as compared to standard amplifiers. In the future, we’ll see more complex instrumentation- and difference amps that take advantage of zero-drift functionality to provide designers more design options for their applications.

Wider range of supply and input voltages is a trend that challenges op amps more than any other system component. High supply-voltage amps are powered by systems that connect to power systems, automobiles, or large battery packs. In these systems, the amplifier’s input may be connected to hundreds of volts and must still amplify signals in the microvolt range. These amps have evolved over the years to include features such as integrated input OVP (over-voltage protection), on-chip EMI (electromagnetic interference) filtering, higher ESD (electrostatic discharge) immunity, and greater resistance to latch-up in both powered and unpowered operations.

Increasingly, high-voltage amplifiers also offer features to improve system performance, cost, and robustness, while easing the complexity of system design in applications ranging from portable telecommunication equipment, power-supply control and protection, and interfaces for transducers with wide output ranges. In the coming years, additional current-sense, instrumentation, and other specialty amps with wide supply-voltage capability will be introduced into the market, offering designers a significant step forward in functionality.

Amplifiers really are the hidden heroes of most electronic systems, and the highly versatile op amp not only fills an extremely important role within the electronics industry, but its evolution is spawning new ways of signal conditioning that can be applied more broadly across many classes of amplifiers that in turn are used in many different applications. Two key capabilities we see spreading even more broadly over the market in the coming year are the inclusion of zero-drift and wide supply-voltage features in a growing range of specialty amplifiers. ■

Steve Sockolov is director of Linear and RF Core Marketing, Analog Devices - www.analog.com - He can be reached at steve.sockolov@analog.com

now available on iPad



free iPad App :

<http://itunes.apple.com/be/app/eetimes/id402418329?mt=8>

Automotive Electronics



EE Times
europe
AUTOMOTIVE

Analog

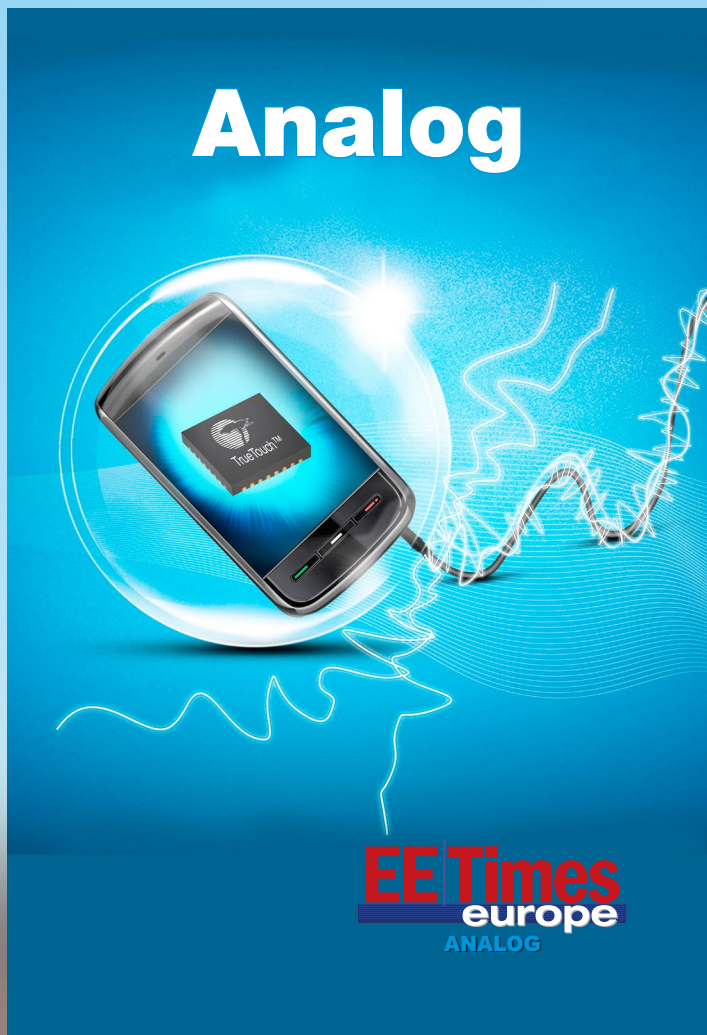

EE Times
europe
ANALOG

LED Lighting

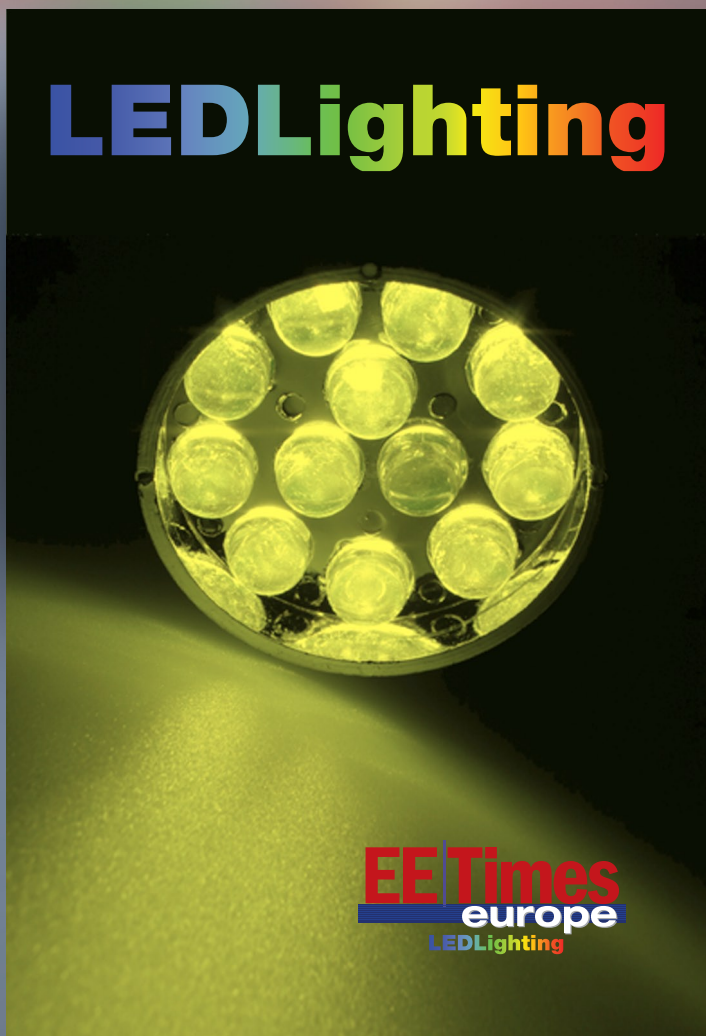

EE Times
europe
LED Lighting

Power Management



EE Times
europe
POWER MANAGEMENT